

PAPER NAME

Peat ecosystem restoration_SimilarityTest.pdf

AUTHOR

tatan sukwika

WORD COUNT

3883 Words

CHARACTER COUNT

22841 Characters

PAGE COUNT

8 Pages

FILE SIZE

613.9KB

SUBMISSION DATE

Jun 2, 2023 7:47 PM GMT+7

REPORT DATE

Jun 2, 2023 7:48 PM GMT+7

● 3% Overall Similarity

The combined total of all matches, including overlapping sources, for each database.

- 3% Publications database
- 0% Submitted Works database
- Crossref Posted Content database

● Excluded from Similarity Report

- Internet database
- Bibliographic material
- Cited material
- Crossref database
- Quoted material

PAPER • OPEN ACCESS

Institutional network of the peat ecosystem restoration plan in Riau Province: Hierarchy and classification approaches

To cite this article: T Sukwika *et al* 2022 *IOP Conf. Ser.: Earth Environ. Sci.* **976** 012019

View the [article online](#) for updates and enhancements.

You may also like

- [Morphology and fruit quality characters of Pineapple \(*Ananas comosus* L. Merr\) cv. Queen on three sites planting: freshwater peat, brackish peat and alluvial soil](#)
Rosmaina, MA Almaktur, R Elfianis et al.
- [Development Paludiculture on Tropical Peatland for Productive and Sustainable Ecosystem in Riau](#)
S R Prastyaningsih, S Hardiwinoto, C Agus et al.
- [Formulating peatland fire prevention strategy in Bengkalis Regency: An application of analytical hierarchy process](#)
S I Maulana, L Syaufina, L B Prasetyo et al.



The Electrochemical Society
Advancing solid state & electrochemical science & technology

242nd ECS Meeting

Oct 9 – 13, 2022 • Atlanta, GA, US

Abstract submission deadline: **April 8, 2022**

Connect. Engage. Champion. Empower. Accelerate.

MOVE SCIENCE FORWARD



Submit your abstract



Institutional network of the peat ecosystem restoration plan in Riau Province: Hierarchy and classification approaches

T Sukwika, L Febrina and I Mulyawati*

Department of Environmental Engineering, Sahid University Jakarta, Jakarta 12870, Indonesia

* Corresponding author e-mail: iramulyawati@gmail.com

Abstract. Government institutions, both central and local, have issued many policies and regulatory products related to tropical peatland management. Still, peatland degradation and conversion and even land fires continue to occur in Riau. The role of an effective and synergistic institutional network is essential and strategic for its existence. This paper analyzes the dominant role of key institutions in the arena of action for the peat ecosystem restoration plan and formulates a model of the institutional network. The method used is applying systematic and iterative graphic theory with institutional analysis tools, namely ISM or Interpretative Structure Modeling. The study results obtained three classifications of peat ecosystem restoration institutional networks based on critical institutions' main tasks and functions: institutional coordination, cooperation, and assistance/guidance programs. The conclusion drawn is that based on the institutional network model, it is known that cooperative institutions facilitate the maturation of the concept of peat restoration against the jointly planned program. The policy implication is strengthening the synergy of multi-stakeholder institutions formed as a critical factor in the management of sustainable peat restoration.

Keywords: institutional, ISM, peatland, restoration, sustainability.

1. Introduction

Forested tropical peatlands are crucial global carbon sinks and biodiversity conservation but are rapidly converted to agriculture or degraded to non-forested vegetation prone to fires [1-3]. Peat damage from wrong land-use policies has resulted in widespread peatland degradation [4,6]. Thus, the restoration of degraded peat ecosystems is an essential issue in Indonesia's peatland protection policy. In early 2016, the Government of Indonesia launched a particular policy on peat restoration. This policy aims to accelerate the recovery and restoration of the hydrological function of peat caused by forest and land fires, especially in 2015. An ad hoc institution called the Peat Restoration Agency (*Badan Restorasi Gambut/BRG*) was established based on Presidential Regulation No. 1/2016. The task of BRG is to coordinate and facilitate peat restoration. In seven provinces with extensive peat ecosystems. Such as Riau, Jambi, South Sumatra, West Kalimantan, Central Kalimantan, South Kalimantan, and Papua.

The area of Riau province is 9,004,209 Ha, with 3,843,374 Ha being a peat hydrological unit area. In the action plan for peat restoration in Riau province, it is stated that it is planned to establish a peat management institution. The peat management at the site level to optimize the roles and functions of the regional peat restoration team (*Tim Restorasi Gambut Daerah/TRGD*) of Riau province and the technical implementation unit (Unit Pelaksana Teknis/UPT) of the forest management unit (*Kesatuan Pengelolaan Hutan/KPH*). This action plan is in the context of accelerating area recovery and restoring



the hydrological function of peat due to forest and land fires in a specific, systematic, directed, integrated and comprehensive manner.

The BRG has a specific task to coordinate and strengthen policies for the implementation of peat restoration; planning, controlling, and cooperating in the implementation of peat restoration; mapping of peat hydrological units; stipulation of zoning for protection and cultivation functions; implementation of infrastructure development for rewetting peatlands and all its facilities; reorganization of the management of burned peatlands; implementation of socialization and education on peat restoration; and supervise the construction, operation, and maintenance of infrastructure on concession lands.

In Law Number 23 of 2014 concerning Regional Government, the authority is divided between the centre and the provinces—regencies/municipalities, where and this Law clarifies that coordination authority is strengthened at the Governor level. For forestry affairs, the Governor gives a significant portion of coordination compared to the previous Law. This Law affects many other authorities, such as licensing, forest area management, and spatial planning. The institutional mechanism is carried out in several stages, including identifying institutions' policies, duties, functions, and cooperation and coordination between related institutions. Identification and analysis of policies, currently Law No. 23 of 2014 concerning Regional Government has been enacted. This Law affects many other authorities such as licensing, forest area management, and spatial planning carried out by cross-institutions, namely those related to forestry, land, agriculture, and spatial planning.

The existence of institutions in local government has a relationship with each other. This condition is undoubtedly essential and strategic in the success of the peat ecosystem restoration plan (RREG) program in Riau Province. So that institutional analysis is needed to help map each government agency's main tasks and authorities [7, 11]. Institutional analysis is used to determine the structure and mechanism of social order and cooperation to shape behaviour within groups and between groups [2,19]. Institutional aspects are in government and non-government institutions, depending on the interests [7, 10]. The role of this institutional aspect is crucial in terms of decision-making mechanisms in peat ecosystem restoration [3]. This study aims to identify the dominant role of key institutions in the arena of action for the peat ecosystem restoration plan and formulate an institutional model for developing the peat ecosystem restoration plan.

2. Study Sites and Methods

This study uses expert sampling taken from stakeholders as key informants. The determination of the respondent sample from the key informants was carried out by purposive sampling and with the snowball sampling technique, namely the sampling technique of data sources that were initially small in number, gradually becoming large [18]. The peat ecosystem restoration plan (*Rencana Restorasi Ekosistem Gambut/RREG*) was carried out in the peat hydrological area of Riau province (Figure 1).

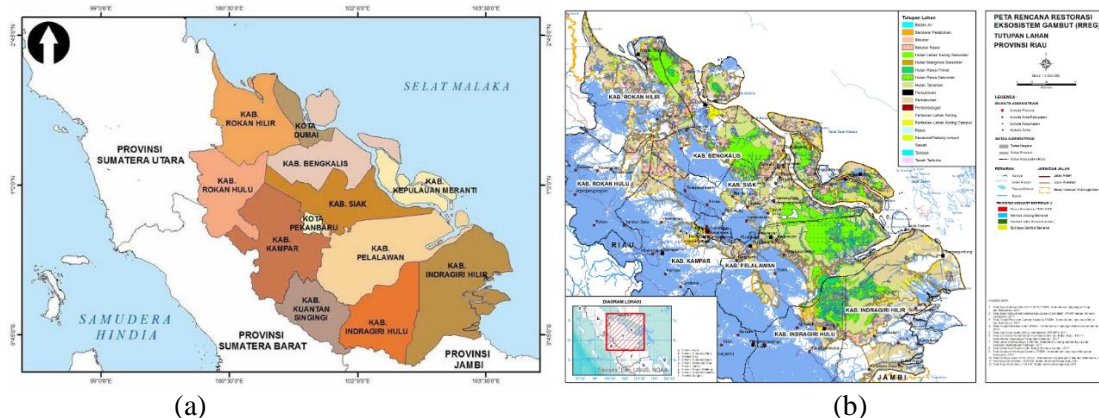

Figure 1. Riau province map (a), Riau province KHG land cover map.

This institutional analysis emphasizes planning, implementation, and monitoring; therefore, the actors chosen as key informants are from institutions directly involved in policymaking and making. Stakeholders involved in the RREG program in Riau Province consist of elements of local government institutions. The elements of the regional command institutions include the Regional Development Planning Agency (Bappeda) of the Riau province (code: E1), the National Land Agency (BPN) of the Riau province, the Public Works Office (PU) of the Riau province, the Forestry Environment Service (LHK) of the Riau province, Riau Province Agriculture Office, Riau Province Plantation Office, Riau Province Natural Resources Conservation Center (BKSDA), Riau Province Production Forest Management Unit (KPHP), Riau Province Regional Peat Restoration Team (TRGD), Riau Province Universities, Non-Governmental Organizations (NGOs) environment of Riau province, Village within the Peat Hydrological Unit (*Kesatuan Hidrologis Gambut/KHG*), Forest Area Stabilization Center (BPKH) Region XIX Pekanbaru, Watershed Management Center (BPDAS) of Riau province, concession area permit holder, City and Regency Government in Riau province, Service Technical Implementation Unit (UPT), and village cares for peat (DPG) community group.

The institutional analysis tool in the preparation of this RREG uses Interpretative Structure Modeling approach (ISM). ISM is one of the structuring tools in descriptive modelling techniques. This ISM technique serves as a helpful knowledge base for planning development strategies for integrated peat ecosystem restoration management, both cross-actor and cross-sectoral through institutions. ISM is a technique used in modelling that can synchronize experts' opinions in providing a concrete picture of the hierarchical structure of the sub-elements of each system element, including finding key sub-elements and the character of each sub-element [17].

Assessment of contextual relationships in pairwise comparison matrices using symbols [16]:

V if $e_{ij} = 1$ and $e_{ji} = 0$ A if $e_{ij} = 0$ and $e_{ji} = 1$

X if $e_{ij} = 1$ and $e_{ji} = 1$ O if $e_{ij} = 0$ and $e_{ji} = 0$

Information:

The value of $e_{ij} = 1$ is a contextual relationship between the i -th and j -th sub-elements. the value of $e_{ij} = 0$ is that there is no contextual relationship between the i -th and j -th sub-elements

The ISM technique is one of the systems modelling techniques to deal with the hard-to-change habits of long-term planning that often apply directly to operational research techniques and descriptive statistics. ISM is concerned with interpreting a complete object or system representation through graph theory's systematic and iterative application. There are nine program elements [16]: (1) The affected community sector, (2) The needs of the program, (3) The main constraints, (4) Possible changes, (5) The objectives of the program, (6) Benchmarks to assess each goal, (7) Activities required for action planning, (8) Activity measures to evaluate the results achieved by each activity, (9) Institutions involved in program implementation.

The results of the ISM then used content analysis to describe the institution qualitatively. The analysis was conducted on the interaction of sub-elements of peat ecosystem restoration institutions both vertically and horizontally. The emphasis is on coordination, institutional authorization, and cooperation between institutions in implementing peat ecosystem restoration. This technique is an abstract qualitative verification strategy for analyzing qualitative data [9].

3. Results And Discussion

The Structural cell-interaction matrix (SSIM) results classified 18 groups into six levels based on the factors influencing institutional function in the Riau Province RREG. The classification of the six levels is detailed as follows: (a) Level I, namely E7 (BKSDA), E8 (KPHP Riau), and E15 (concession area permit holder); (b) Level II, namely E10 (Universities), E11 (Environmental NGOs); (c) Level III is E1 (Bappeda), E3 (Department of Public Works), E5 (Department of Agriculture), E6 (Department of Plantations), and E14 (BPDAS); (d) Level IV, namely E2 (BPN), E13 (BPKH Reg. XIX Pekanbaru);

(e) Level V, namely E12 (Village in KHG), E17 (UPT), and E18 (DPG Community Group); and (f) Level VI, namely E4 (LHK Office), E9 (TRGD) and E16 (City/Regency Government in Riau province).

The output of the ISM-VAXO model shows a hierarchical structure of the relationship between the supporting sub-elements consisting of 6 levels with the assumption that the relationship between one supporting sub-element affects the benefits of another supporting sub-element. Structurally, there are 6 (six) dominant actors from levels 4-6. Of the six dominant actors, the key (most dominant) actors in the RREG in Riau Province are the LHK Service, TRGD, and City/Regency Governments in Riau province, occupying the highest level (level 6) with the largest total DP (driven power). Its position has the highest driving force so that this TRGD sub-element is a key sub-element of the elements of possible change. The model hierarchy means that the sub-elements at a level are supported by fulfilling the sub-elements at the lower level [16,17]. The model's output shows that the position of the sub-elements of extension institutions plays a significant role in motivating and inviting the community to participate in managing peat restoration. This TRGD largely determines the role of local communities and the performance of government programs. Communities have an essential role, but local government units have a greater responsibility to provide the policy and institutional basis to support community-based initiatives [19]. According to Maulana *et al.* [12], To support local governments in preparing a more proactive prevention approach in dealing with peatland fires, a financing scheme is needed in the form of providing no-burn incentives for traditional cultivators in addition to providing infrastructure in the form of construction and or repair of reservoirs and boreholes [14]. Meanwhile, Hansson and Dargusch [8] emphasize the need for a classification scheme for restoration activities based on fire, drainage, and history of logging in peatland areas. The scheme helps identify the need for initial gross financial costs for restoration activities in various locations.

The absence of synergistic peat protection and management plan at the national and regional levels makes it difficult to implement targeted protection. Different maps and data are one of them [15]. After the big fire in 2015, the Peatland Restoration Agency (BRG) was tasked with restoring. Peat restoration is carried out through three approaches: rewetting, revegetation, especially in burned areas, and revitalizing livelihoods [4,5].

In principle, BRG already has a peat restoration action plan compiled in a planning document called the Peat Ecosystem Restoration Plan (RREG). However, in its implementation, BRG still needs to coordinate with various parties to accelerate restoration. It is related to the distribution of peat locations that are the target of peat restoration. BRG has many locations that are not entirely accessible by BRG.

The extent of degraded peatlands also requires stronger and coordinated institutions and personnel to restore them. These are all critical agenda items to be considered in future national and regional policies. Therefore, regional peat restoration teams (TRGD) have been formed in the regions to facilitate technical operations, chaired by regional secretaries in each province. In its implementation, TRGD coordinates, cooperates, and exchanges information with local stakeholders. Both among actors, across institutions, and regions within the administrative area of Riau Province.

RREG institution consists of three institutional focuses are based on main tasks and functions: Coordination, Collaboration, and Assistance/Guidance Programs. For example, coordination institutions can resolve community land ownership problems within the Peat Hydrological Unit (KHG) area. For example, the TRGD coordinated with the Forest Area Stabilization Center (BPKH) for Region XIX Pekanbaru to identify the statuses of the area within the KHG in the form of claims for rights and claims by the community. In general, evidence of the type of land ownership (letter of land rights) by the community in Riau Province, among others, (a) Land Certificate (BPN), (b) Land Certificate (SKT), (c) Statement Letter of Recognition of Land Rights (SPH), (d) Cutting Permit (SIT) or Cutting Permit (SIP), and (e) Certificate of Energy Compensation on SEAL paper. By the Regulation of the Minister of Forestry P.44/Menhut-II/2012 jo. P.62/Menhut-II/2013 concerning the Inauguration of Forest Areas, it is stated that land that has legal evidence or proof of claim has the potential to be released from state forest land. Furthermore, TRGD coordinates with BPN, authorized to verify the evidence of claims from the public, both legal and otherwise. The flow of coordination, collaboration and assistance across institutions can be seen in Figure 2.

The TRGD, the Public Works Agency, Bappeda, and DLKH agreed on several things, for example, coordination and synchronization of precise location determination of peatland restoration, exchange of data and information, peat restoration planning, implementation of peat restoration construction and monitoring and evaluation. The cooperation agreement can serve as a guideline for both parties and parties to carry out planning, construction, and monitoring activities for peat restoration through the development of peat wetting infrastructure in the form of canal blocking, canal filling, and other wetting technologies [2,5,11,15].

Institutional cooperation can be used by institutions that require the maturation of the concept of the program that has been planned. For example, to determine the most effective and acceptable paludiculture farming program for the community in the context of launching a peat restoration program [5], of course, more in-depth and comprehensive academic studies are needed. Not all city/district areas have the same conditions and materials on peatlands so that the suitability and suitability of plants also vary in each region [13]. The types of plants found on peatlands include oil palm, rubber, acacia, areca nut, sago, jelutong, dragon fruit, pineapple, cassava, peanut, soybean, corn, sweet potato, asparagus, rice, and vegetables. In this case, the role of universities can be partners of cooperation by other institutions. The application of paludiculture in Indonesian tropical peat is known that certain commodities are more resistant to inundation but still has economic value. Such as *Metroxylon* spp., *Nypa fruticans* Wurmb, *Alseodaphne* spp., *Nothaphoebe* spp., and *Shorea* spp.

Assistance/guidance programs such as non-governmental organizations provide socialization assistance related to peat restoration to village communities and peat care community groups. Institutional assistance/guidance programs can also be carried out by permit holders whose areas are in the peat hydrological area (KHG) through CSR (corporate social responsibility) programs or empowerment of village communities who care about peat. One model of community empowerment development carried out by Adjie [1] assistance to the "Village Cares for Peat" is related to the 3R (Rewetting, Revegetation, and Revitalization).

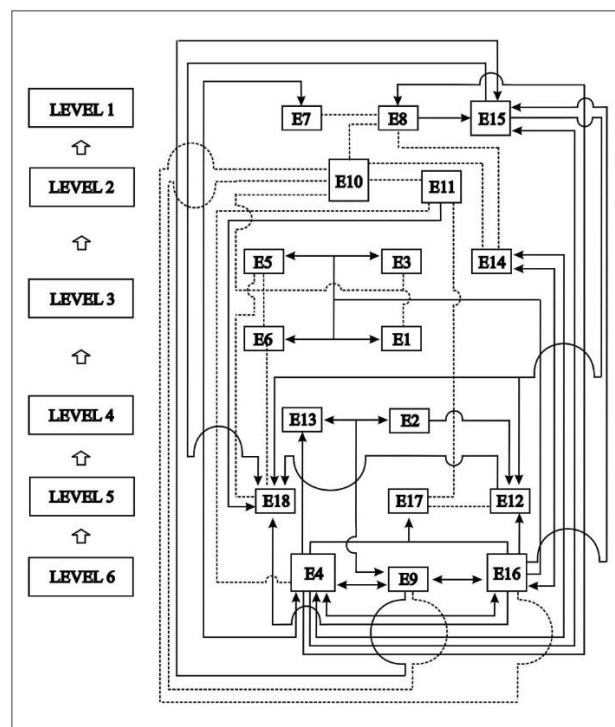



Figure 2. Hierarchical Structure of the Role of Each Institution in the Riau Province RREG Policy Information :

----- = Collaborate

-  = Coordination
 = Assistance/Construction Program

Code Meaning:

- | | |
|---|---|
| E1 = Bappeda Regional Staffing Agency | E10 = University |
| E2 = National Land Agency | E11 = Environmental Non-Governmental Organization |
| E3 = Public Works Office | E12 = Village in Peat Hydrological Unit |
| E4 = Department of Environment and Forestry | E13 = Pekanbaru XIX Regional Forest Area Consolidation Center |
| E5 = Department of Agriculture | E14 = Watershed Management Center |
| E6 = Plantation Office | E15 = Concession area permit holder |
| E7 = Natural Resources Conservation Center | E16 = City/Regency Government in Riau province |
| E8 = Unit of Production Forest Management riau province | E17 = Service Technical Implementation Unit |
| E9 = Regional Peat Restoration Team | E18 = Village Community Group Cares for Peat |

Finally, so far, the community has only participated in the implementation of rehabilitation measures. Therefore, to maintain community development and sustainable peat management, it is necessary to reform the institutional structure of multi-stakeholder governance that ensures the active participation of local communities [11,20,21]. Implementation of Indonesia's peat regulations has consistently been implemented. However, it still does not cover all aspects of the crime of environmental destruction and pollution due to forest and land fires. Of course, this makes an essential contribution to mitigating peat fires. The lack of socialization about the content of regulations and alternative best practices on peatlands and the lack of field monitoring are the leading causes of non-compliance with peatland regulations. In the future, strong and synergized multi-stakeholder institutions will be the main determining factor for sustainable peat restoration management. However, the role of local community groups cannot be ignored [15].

4. Conclusion

The dominant role of key institutions in the arena of action for the peat ecosystem restoration plan (RREG) in Riau province is the environmental and forestry service (LHK), the regional peat restoration team (TRGD) and city and district governments in Riau province. The three institutions have extreme and large driven power. The position has the highest driving force to provide possible initial changes to the established institutional network. In the short term, the institutional direction is prioritized on peatlands' condition, function, and spatial planning. The institutional network model formulation results for developing peat ecosystem restoration plans are focused on institutional coordination, cooperation, and assistance/guidance programs. The institutional network model is believed to facilitate stakeholders in maturing the concept of peat restoration against the jointly planned program. Institutional coordination constraints are often caused by the absence of synergistic peat protection and management plan between institutions, such as the availability of different maps and data at the national and regional levels in each institution, making it challenging to implement targeted protection. Therefore, in the future, strengthening the synergy of the multi-stakeholder institutions that have been formed will be a critical factor in the management of sustainable peat restoration.

Acknowledgments

The authors gratefully thank the governments, officials, experts, villagers and all respondents in Riau for their contributions and help in conducting this research. We would like to thank Badan Restorasi Gambut RI. The authors would like to thank the reviewers for their helpful comments.

References

- [1] Adji F F, Darung U, and Silva K M 2020 *Jurnal Informasi* **72** 26-34
- [2] Arts B and Buizer M 2009 *Forest policy and economics* **115**(6) 340-347
- [3] Blackham G V, Webb E L and Corlett R T 2014 *Forest Ecology and Management* **32**(4) 8-15
- [4] BRG 2017 Contingency plan – BRG restoration target based on priority restoration criteria (Jakarta: Peatland Restoration Agency)
- [5] Clarke D and Rieley J 2010 *Strategy for responsible peatland management* (Finland: International Peat Society)
- [6] Dohong A, Aziz A A, and Dargusch P 2017 *Land use policy* **69** 349-360
- [7] Fischer F and Miller G J 2017 *Handbook of public policy analysis: theory politics and methods* (Florida: Routledge)
- [8] Hansson A, and Dargusch P 2018 *Case studies in the environment* **2**(1) 1-8
- [9] Hashemnezhad H 2015 *Journal of ELT and Applied Linguistics JELTAL* **31** 54-62
- [10] Horlings I, and Padt F 2013 *Sustainable Development* **216** 413-424
- [11] Lounsbury M 2008 *Accounting Organizations and Society* **334**(5) 349-361
- [12] Maulana S, Syaufina L, Prasetyo L and Aidi M 2019 *Formulating peatland fire prevention strategy in Bengkalis Regency: An application of analytical hierarchy process* Paper presented at the IOP Conference Series: Earth and Environmental Science
- [13] Muslimin I 2018 *Kajian paludikultur untuk restorasi lahan gambut bekas kebakaran di kabupaten Oki Sumatera Selatan* (Palembang: BP2LHK)
- [14] Page S, Hoscilo A, Langner A, Tansey K, Siegert F, Limin S and Rieley J 2009 Tropical peatland fires in Southeast Asia In *Tropical fire ecology* (Berlin: Springer)
- [15] Safitri M A 2018 *Peatland Restoration and Transboundary Haze Pollution: Law and Institutional Change in Indonesia* Paper presented at the Harmonization of Asean Law to Actualize The Asean Economic Community” Bengkulu 11-12 October 2018 Universitas Bengkulu
- [16] Saxena J P, Sushil, and Vrat P 1992 *Systems Practice* **56** 651-670
- [17] Saxena J P, Sushil and Vrat P 2006 *Policy and strategy formulation: An application of flexible systems methodology* (New Delhi: GIFT Publishing)
- [18] Sugiyono 2017 *Methods of quantitative qualitative and Rand* (Bandung: Alfabeta)
- [19] Sukwika T 2018 *ournal of Regional and Rural Development Planning* **2**(2) 133-150
- [20] Sukwika T, Yusuf D N, and Suwandhi I 2020 *Jurnal Manajemen Hutan Tropika* **26**(1) 59-71
- [21] Sukwika T and Fransisca L 2021 *Indonesian Journal of Forestry Research* **8**(2) 135-157

● 3% Overall Similarity

Top sources found in the following databases:

- 3% Publications database
- 0% Submitted Works database
- Crossref Posted Content database

TOP SOURCES

The sources with the highest number of matches within the submission. Overlapping sources will not be displayed.

- 1** **St Sabahannur, Suraedah Alimuddin, St Subaedah, Nurul Wahdaniya, Fi...** **3%**
Crossref posted content

- 2** **M. Devi, S. Das, A. Medhi, S. Patgiri, A. K. Barbara, K. I. Oyama. "Earthq...** **<1%**
Crossref posted content