

Submit a Proposal

Journal Content

Search

Search Scope

All

Search

Browse

- » By Issue
- » By Author
- » By Title
- » By Sections
- » Other Journals

Notifications

- » View (16 new)
- » Manage

TOOLS

Download LJFR for Android here



VISITOR STATISTICS

00492718



Home / User / Author / Submissions / #6121 / Review

#6121 Review

Summary | Review | Editing

Submission

Authors Tatan Sukwika, Lidya Fransisca
Title THE POLICY MODEL FOR SUSTAINABLE COMMUNITY FOREST: A FACTOR ANALYSIS
Section Articles
Editor Dian Indrawan

Peer Review

Round 1

Review Version [6121-30297-2-RV.docx](#) 2020-11-17

Initiated 2020-11-17

Last modified 2020-11-25

Uploaded file None

Editor Version [6121-30529-1-ED.docx](#) 2020-11-17
[6121-30529-2-ED.docx](#) 2020-11-27

Author Version None

Round 2

Review Version [6121-30297-3-RV.docx](#) 2020-11-27

Initiated 2020-11-27

Last modified 2021-03-25

Uploaded file Reviewer C [6121-33063-1-RV.docx](#) 2021-03-25
Reviewer C [6121-33063-2-RV.pdf](#) 2021-03-25
Reviewer A [6121-32042-1-RV.docx](#) 2021-01-28
Reviewer A [6121-32042-2-RV.pdf](#) 2021-01-28

Editor Version [6121-30529-3-ED.docx](#) 2020-11-27

Author Version [6121-33158-1-ED.docx](#) 2021-04-04

Round 3

Review Version [6121-30297-4-RV.docx](#) 2021-04-05

Initiated 2021-04-05

Last modified 2021-05-17

Uploaded file Reviewer B [6121-33714-1-RV.docx](#) 2021-05-17
Reviewer B [6121-33714-2-RV.pdf](#) 2021-05-17
Reviewer A [6121-33217-1-RV.docx](#) 2021-04-08
Reviewer A [6121-33217-2-RV.pdf](#) 2021-04-08

Editor Version [6121-30529-4-ED.docx](#) 2021-04-05

Author Version [6121-33158-2-ED.docx](#) 2021-05-23

Round 4

Review Version [6121-30297-5-RV.docx](#) 2021-05-31

Initiated 2021-05-31

Last modified 2021-08-21

Uploaded file Reviewer B [6121-35150-1-RV.docx](#) 2021-08-21
Reviewer A [6121-34234-1-RV.docx](#) 2021-06-26
Reviewer A [6121-34234-2-RV.pdf](#) 2021-06-26

Editor Version [6121-30529-5-ED.docx](#) 2021-05-31

Author Version [6121-33158-3-ED.docx](#) 2021-08-22

Round 5

Review Version [6121-30297-6-RV.docx](#) 2021-09-10

Initiated 2021-09-10

Last modified 2021-09-30

Uploaded file Reviewer A [6121-35754-1-RV.docx](#) 2021-09-30
Reviewer A [6121-35754-2-RV.pdf](#) 2021-09-30

Editor Decision

Decision Accept Submission 2021-10-25

Notify Editor Editor/Author Email Record 2021-09-30

Editor Version [6121-30529-6-ED.docx](#) 2021-09-10
[6121-30529-7-ED.docx](#) 2021-10-25

Author Version [6121-33158-4-ED.docx](#) 2021-09-30 [Delete](#)

Upload Author Version No file selected.

User

You are logged in as...
tatan

- » My Journals
- » My Profile
- » Log Out



REFERENCE TOOLS

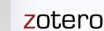
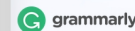

THE MODEL OF POLICY FOR SUSTAINABLE COMMUNITY FOREST: A FACTOR ANALYSIS

Received: Revised: Accepted: (Filled by IJFR)

THE MODEL OF POLICY FOR SUSTAINABLE COMMUNITY FOREST: A FACTOR ANALYSIS. Developing and maintaining sustainable forest is a way to support sustainable development. In the technical point of view, the sustainability of community forest could be articulated not only base on the three aspects i.e. economic (ECO), social culture (SOC), ecology (EGY), but it also includes dimensions of legal & institutional (LIT), and accessibility & technology (ACT). This study aims to determine variables of sustainability dimension that have a direct positive effect on the sustainability of community forests (SCF), to identify variables that affect SCF and variables of sustainability dimension that has the effect of dominant on SCF. This study employed 70 samples of forest farmers' group in Bogor regency. The respondents were purposively selected based on consideration of the criteria for forest farmer groups namely beginner, intermediate, and main criteria. The Analysis tools using PLS-SEM. Sustainability dimensions of ECO, EGY, LIT, and ACT have a significant positive direct effect on SCF. The mediational hypothesis testing suggested that there is a partial mediation from ECO and EGY to SCF, which is consistent and have a positive value. Based on the coefficient value of the total-effect, among the five dimensions, ecology value was the biggest and the most robust. The policy implies that the ecological aspects are considered the importance and strategic. Therefore, the value and productivity of the community forest structure and composition need to be maintained.

Developing and maintaining sustainable forest is a way to support sustainable development. In the technical point of view, the sustainability of community forest could be articulated more beyond not only base on those the three aspects i.e. such as economic (ECO), social culture (SOC), ecology (EGY), but it also includes dimensions of legal & institutional (LIT), and accessibility & technology (ACT). This study aims to determine variables of sustainability dimension that have a direct positive effect on the sustainability of community forests (SCF), to identify variables that affect SCF and variables of sustainability dimension that has the effect of dominant on SCF. This study employed 70 samples of forest farmers' group in Bogor regency. The respondents were purposively selected based on consideration of the criteria for forest farmer groups namely beginner, intermediate, and primary main criteria. The Analysis tools using PLS-SEM. Sustainability dimensions of ECO, EGY, LIT, and ACT have a significant positive direct effect on SCF. The mediational hypothesis testing suggested that there is a partial mediation from ECO and EGY to SCF, which is consistent and have a positive. Based on the calculation of the coefficient value of the total effect, among the five dimensions, ecology value was the biggest and the most robust. The policy implies that the ecological aspects are considered the importance and strategic. Therefore, the value and productivity of the community forest structure and composition need to be maintained.

Keywords: Direct-indirect effect, effect mediation-total, PLS-SEM, sustainability of community forests

MODEL KEBIJAKAN HUTAN MASYARAKAT BERKELANJUTAN: ANALISIS FAKTOR. Mengembangkan dan memelihara hutan lestari merupakan salah satu cara untuk mendukung pembangunan berkelanjutan. Secara teknis, kelestarian hutan masyarakat dapat diartikulasikan tidak hanya dari tiga aspek, yaitu ekonomi (ECO), sosial budaya (SOC), ekologi (EGY), namun juga termasuk dimensi legal & institusional (LIT), dan aksesibilitas & teknologi (ACT). Penelitian ini bertujuan untuk menentukan variabel dimensi keberlanjutan yang berpengaruh langsung positif terhadap kelestarian hutan masyarakat (SCF), mengidentifikasi variabel yang mempengaruhi SCF dan variabel dimensi keberlanjutan yang berpengaruh dominan terhadap SCF. Penelitian ini menggunakan sampel 70 kelompok tani hutan di kabupaten Bogor. Responden dipilih secara sengaja didasarkan pada pertimbangan kriteria kelompok tani hutan yaitu kriteria pemula, madya, dan utama. Alat analisis yang digunakan adalah PLS-SEM. Dimensi keberlanjutan ECO, EGY, LIT, dan ACT berpengaruh langsung positif signifikan terhadap SCF. Pengujian hipotesis mediasi menunjukkan bahwa terdapat mediasi parsial dari ECO dan EGY ke SCF yang konsisten dan bernilai positif. Berdasarkan perhitungan nilai koefisien total-effect, diantara kelima dimensi tersebut, nilai ekologi merupakan yang terbesar dan terkuat. Implikasi kebijakannya, aspek ekologi dianggap penting dan strategis. Oleh karena itu, struktur dan komposisi hutan masyarakat perlu dijaga nilai dan produktivitasnya.

Mengembangkan dan memelihara hutan lestari merupakan salah satu cara untuk mendukung pembangunan berkelanjutan. Secara teknis, kelestarian hutan masyarakat dapat diartikulasikan

tidak hanya lebih dari tiga aspek, yaitu ekonomi (ECO), sosial budaya (SOC), ekologi (EGY), namun juga termasuk dimensi legal & institusional (LIT), dan aksesibilitas & teknologi (ACT). Penelitian ini bertujuan untuk menentukan variabel dimensi keberlanjutan yang berpengaruh langsung positif terhadap kelestarian hutan masyarakat (SCF), mengidentifikasi variabel yang mempengaruhi SCF dan variabel dimensi keberlanjutan yang berpengaruh dominan terhadap SCF. Penelitian ini menggunakan sampel 20 kelompok tani hutan di kabupaten Bogor. Responden dipilih secara sengaja berdasarkan pada pertimbangan kriteria kelompok tani hutan yaitu kriteria pemula, madya, dan utama. Alat analisis digunakan PLS-SEM. Dimensi keberlanjutan ECO, EGY, LIT, dan ACT berpengaruh langsung positif signifikan terhadap SCF. Pengujian hipotesis mediasi menunjukkan bahwa terdapat mediasi parsial dari ECO dan EGY ke SCF yang konsisten dan bernilai positif. Berdasarkan perhitungan nilai koefisien total effect, diantara kelima dimensi nilai ekologi merupakan yang terbesar dan terkuat. Implikasi kebijakannya, aspek ekologi dianggap penting dan strategis. Oleh karena itu, struktur dan komposisi hutan masyarakat perlu dijaga nilai dan produktivitasnya.

Kata kunci: Efek langsung-tidak langsung, efek mediasi-total, PLS-SEM, kelestarian hutan masyarakatnya

I. INTRODUCTION

Developing and maintaining sustainable forest is a way to support sustainable development. Sustainable development pillar was based on three aspects, namely economic, social, and ecology. As pointed out in the 2015 World Summit, those aspects are inter-linked one of another, and also have an important role in promoting sustainable development (G-Assembly, 2005). The relation between those three aspects is not only mutually exclusive but also mutually reinforcing. In the context of community forest sustainability in this case private-forest, the economy-social-ecology aspects have a causal relationship. In the technical point of view, the community forest sustainability could be articulated more beyond those three aspects. Some studies had addressed five aspects or dimension of sustainability: (1) economic; (2) social & culture; (3) ecology; (4) legal & institution; and (5) accessibility & technology (Apipoonyanon et al., 2020; Baral et al., 2018; Ekanayake et al., 2020; Sukwika et al., 2016; Sukwika et al., 2020; Tadesse & Teketay, 2020). In the sustainable development scheme, the relation among the three aspects will form equitable, viable, and bearable as resulted from the economic-social, economic-ecology, and social-ecology relation (Munasinghe, 1992), respectively (Figure 1). Meanwhile, the role of the other two aspects (legal & institution and accessibility & technology) acted as a bridge to identify the factors that could not be reflected by the three aspects.

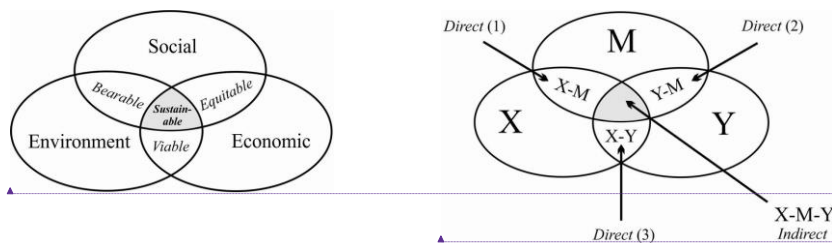

Formatted: Font: Garamond

Formatted: Font: Garamond

Figure 1. Three Pillars and their relationships in the Sustainable Development Scheme

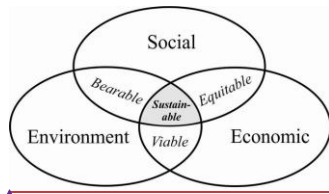

Figure 1. Three Pillars and their relationships in the Sustainable Development Scheme

Figure 2. Mediation model

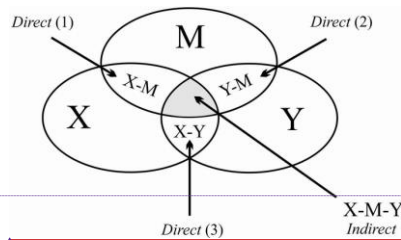

Figure 2. Mediation model

Formatted: Font: Garamond
Formatted: Font: Garamond

This study aims to analyze the impact of the five aspects and their relation (direct and indirect) on community forest sustainability. For that purposes, path analysis approach, a further development of multiple regression was used in this study to estimate the magnitude and significance of causal relationship among variables (MacKinnon et al., 2012; Maslowsky et al., 2015; Sarstedt et al., 2017; Thoemmes et al., 2010; Turnes & Ernst, 2015; Ullman & Bentler, 2013; Vinzi et al., 2010).

Sustainability of community forests in Bogor, indirectly, is a result of connectivity among the sustainability dimensions (Musyoki et al., 2016; Sukwika et al., 2016; Sukwika et al., 2020). It explained that mediation variable M is one that determines the effect between the independent variable and dependent variable (Kenny & Judd, 2014; MacKinnon et al., 2012; Maslowsky et al., 2015; Sarstedt et al., 2017; Turnes & Ernst, 2015; Vinzi et al., 2010) (see Figure 2). There was a more-intensive utilization of moderation and mediation in the statistical analysis state-of-the-art (Paul, 2013). Using moderation concept, for instance, existing in the context of a theory, it was stated that poverty is one of the determinant factors of environmental degradation, as well as negative—exploitative and inefficient—behaviour in natural resources management. On the contrary, degradation of environment support system could be a determinant factor of poverty (Kusmana & Sukwika, 2018; Musyoki et al., 2016; Sukwika et al., 2016; Sukwika et al., 2020; Tadesse & Teketay, 2020). The connectivity as follow: [X] Farmers' purchasing power (Economic) → [M] Consumption and Production Pattern (Ecology) → [Y] Poverty of farmers' household (Social).

Farmers' purchasing power affects farmers' behaviour in managing the forest and other resources, through the mode they carried out consumption and production. The implication on farmers' welfare will be there once using an efficient, as well as a more-wise (not exploitative) mode of consumption and product, and vice-versa. Figure 2 shows that relation between economic (X) and Social (Y) was mediated by ecology (M) so that X-M-Y is namely as a condition of sustainability of community forest/SCF (Dawson, 2014; Holland et al., 2016; Memon et al., 2018; Nitzl et al., 2016; Paul, 2013). This study aims to determine variables of sustainability dimension that have a direct positive effect on the sustainability of community forests (SCF); identify variables that affect SCF; identify variables of sustainability dimension that have a dominant effect to SCF.
This study aims to analyze the impact of the five aspects and their relation (direct and indirect) on community forest sustainability. For that purposes, path analysis approach a further development of multiple regression was used in this study. Path analysis is a further development of multiple regression to estimate the magnitude and significance of causal

relationship among variables (MacKinnon et al., 2012; Maslowsky et al., 2015; Sarstedt et al., 2017; Thoemmes et al., 2010; Turnes & Ernst, 2015; Ullman & Bentler, 2013; Vinzi et al., 2010).

Sustainability of community forests in Bogor, indirectly, is a result of connectivity among the sustainability dimensions (Musyoki et al., 2016; Sukwika et al., 2016; Sukwika et al., 2020). It explained that mediation variable M is one that determines the effect between the independent variable and dependent variable (Kenny & Judd, 2014; MacKinnon et al., 2012; Maslowsky et al., 2015; Sarstedt et al., 2017; Turnes & Ernst, 2015; Vinzi et al., 2010) (see Figure 2). There was a more intensive utilization of moderation and mediation in the statistical analysis state-of-the-art (Paul, 2013). Using moderation concept, for instance, was there existing in the context of a theory, it was stated that poverty is one of the determinant factors of environmental degradation, as well as negative exploitative and inefficient behaviour in natural resources management. On the contrary, degradation of environment support system could be a determinant factor of poverty (Kusmana & Sukwika, 2018; Musyoki et al., 2016; Sukwika et al., 2016; Sukwika et al., 2020; Tadesse & Teketay, 2020). The connectivity as follow:

[X] Farmers' purchasing power (Economic) → [M] Consumption and Production Patterns (Ecology) → [Y] Poverty of farmers' household (Social)
Farmers' purchasing power affects farmers' behaviour in managing the forest and other resources, through the mode they carried out consumption and production. The implication on farmers' welfare will be there once using an efficient, as well as a more wise (not exploitative) mode of consumption and product, and vice versa. The above Figure 2 shows that relation between economic (X) and Social (Y) was mediated by ecology (M) so that X-M-Y is namely as a condition of sustainability of community forest/SCF (Dawson, 2014; Holland et al., 2016; Memon et al., 2018; Nitzl et al., 2016; Paul, 2013). This study aims to determine variables of sustainability dimension that have a direct positive effect on the sustainability of community forests (SCF); identify variables that affect SCF; identify variables of sustainability dimension that have a dominant effect to SCF.

II. MATERIAL AND METHOD

A. Research Location

This research was conducted in the Bogor community forest area. The research was conducted in community forest areas that have forest farmers' group assisted by BP3K (Agricultural, Fisheries and Forestry Extension Center) in Bogor Regency.

B. Methods

The selection of This study employed 70 (seventy) samples of forest farmers' group selected purposively based on certain criteria i.e. forest farmer groups namely beginner, intermediate, and main primary criteria (explain...). A recommended sample size criteria for PLS-SEM (partial least squares structural equation modeling) utilization is somewhere between 30 to 100 (Sarstedt et al., 2017; Ullman & Bentler, 2013; Ursachi et al., 2015). forest farmer groups namely beginner, advanced and intermediate based on BKP5K (Food Security Agency and Implementing Agricultural, Fisheries and Forestry Extension) data, there are 312 forest farmer groups clustered based on four levels of ability. The distribution includes, 107 beginner groups, 160 advanced groups, 42 middle groups, and 3 main groups. Furthermore, 70 respondents or 22 percent of the 312 groups were selected according to group representation proportionally with the details of respondents from the beginner group of 24 farmer people groups (107x22%), advanced as many as 36 farmer groups people (160x22%), intermediate as many as 9 farmer groups people (42x22%), and main as much as 1 person (3x22%). The population was 312 forest farmer groups. The sample of 70 respondents of forest farmers' group was selected purposively, which uses 90 per cent confidence level by using Taro Yamane method, (Ali & Bhaskar, 2016; Singh & Masuku,

- Formatted: Not Highlight
- Formatted: Highlight
- Formatted: Indent: First line: 0 cm
- Commented [A1]: From 70 samples, how is the distribution of the farmer group according to the criteria's? (How many is the beginner, the intermediate, and the primary group?)
- Commented [A2R1]: We have completed, yellow highlight
- Formatted: Highlight
- Commented [A3]: Please write BKP5K completely when write it for the first time, afterwards you can use the abbreviation
- Commented [A4R3]: We have completed, blue highlight
- Formatted: Highlight
- Commented [A5]: People or Group?
- Commented [A6R5]: We have changed to Group, green highlight
- Formatted: Highlight
- Formatted: Highlight
- Formatted: Highlight
- Commented [A7]: People or Group?
- Commented [A8R7]: We have changed to Group, green highlight
- Commented [A9]: People or Group?
- Commented [A10R9]: We have changed to Group, green highlight
- Commented [A11]: You have not yet answered the Comment (A1). You selected farmer groups according to 3 criteria's, but there is no information after you selected the samples, from 70 samples, how many are beginner, how many are intermediate and how many are primary farmer groups?
- Commented [A12R11]: We have completed, yellow highlight
- Formatted: Highlight
- Formatted: Font: 12 pt, Font color: Auto, Highlight
- Formatted: Highlight
- Formatted: Highlight

2014; Yamane, 1967). A recommended sample size criteria for PLS-SEM (partial least squares structural equation modeling) utilization is somewhere between 30 to 100 (Sarstedt et al., 2017; Ullman & Bentler, 2013; Ursachi et al., 2015).

Partial least square is a multivariate statistical technique that can handle many response variables as well as explanatory variables at once. This analysis is a good alternative for multiple regression analysis methods and principal component regression, because this method is more robust. Robust means that the model parameters do not change much when a new sample is taken from the total population. Partial Least Square is also a predictive technique that can handle many independent variables, even if there is multicollinearity between these variables (Costa et al., 2012; Ghozali & Latan, 2015b; Hair et al., 2012, 2013).

which uses 90 per cent confidence level by using Taro Yamane method, which uses 10 per cent tolerance (Ali & Masduki, 2016; Singh & Masduki, 2014; Yamane, 1967).

Partial least square is a multivariate statistical technique that can handle many response variables as well as explanatory variables at once. This analysis is a good alternative for multiple regression analysis methods and principal component regression, because this method is more robust. Robust means that the model parameters do not change much when a new sample is taken from the total population. Partial Least Square is also a predictive technique that can handle many independent variables, even if there is multicollinearity between these variables. ~~least square is a multivariate statistical technique that can handle many response variables as well as explanatory variables at once. This analysis is a good alternative for multiple regression analysis methods and principal component regression, because this method is more robust. Robust means that the model parameters do not change much when a new sample is taken from the total population. Partial Least Square is also a predictive technique that can handle many independent variables, even if there is multicollinearity between these variables~~ (Costa et al., 2012; Ghozali & Latan, 2015a; Hair et al., 2012, 2013).

C. Assumption and Hypothesis

Path analysis is based on the following assumptions: (1) relation among variables is linear and additive; and (2) consider on the model which contains only one-direction causal loop (recursive). Parameter estimation method in PLS is using ordinary least square (OLS), which carried out to each equation, partially. The estimation covers: (1) weight estimate to determine the score of latent variables; (2) path estimate that relationships among latent variables and estimation loading between latent variables and their indicators; and (3) mean and intercept for indicators and latent variables (Cham et al., 2012; Ghozali & Latan, 2015b; Hair et al., 2014; Sarstedt et al., 2017; Ullman & Bentler, 2013; Vinzi et al., 2010). The calculation process is carried out iteratively, ~~where and~~ iteration will be terminated once the convergent condition is attained. The model specification is identified based on theories and relevant concepts.

The goodness of Fit (GoF) model is measured by using R-square of latent dependent variable which same interpretation with that of regression; Q-square predictive relevant for a structural model ~~is used~~, to measure the goodness of observation value ~~that~~ resulted by the model and estimation parameter. Q-square value of > 0 shows that the model has predictive relevance. Convergent validity test ~~is~~ to see the correlation between the score of reflexive indicator and a score of latent variables. For this, loading score of 0.5 – 0.6 is considered sufficient in the case of 3 – 7 indicators for each construct. Discriminant validity is carried out to compare the value of the square root of average variance extracted (AVE) for each construct, with a value of correlation among other constructs in the model. If the construct's AVE is bigger than other construct's correlation, then the model's discriminant validity is good. It is recommended that the value of measurement should be above 0.50. Group of indicators that measure particular should have composite reliability score of 0.7, even though

Formatted: Indent: First line: 0,36 cm

Formatted: Justified, Indent: First line: 0,36 cm

it is not an absolute standard (Ghozali & Latan, 2015b; Hair et al., 2014; Valentini & Damasio, 2016).

Hypothesis testing (β , γ , and λ) is carried out by using a method of bootstrap resampling which was developed by Geisser and Stone in Muller (2013). Statistical testing that be used is t-statistic or t-test, which the hypothesis formulation as follows:

- Statistic hypothesis for an outer model for the feasibility of indicator as a latent variable measurement instrument is $H_0: \lambda = 0$ vs $H_1: \lambda_i \neq 0$.
- Statistic hypothesis for the inner model for the latent effect of the exogenous variable to the endogenous variable is $H_0: \gamma_i = 0$ vs $H_1: \gamma_i \neq 0$.
- Statistic hypothesis for the inner model for the latent effect of the endogenous variable to the endogenous variable is $H_0: \beta_i = 0$ or $H_1: \beta_i \neq 0$.

Application of resampling method provides the possibility of distribution-free data, which is not needed to fulfil normality assumption and big (minimum of 30) sample size. The testing held by t-test, if it obtained p-value= 0.05 (alpha 5%), it could be concluded as a significant, and vice versa. Reliance degree in this research is 95%, which $\alpha = 0.05$, respondent $n=70$. and independent variable $k=1$. With formula to find t table = $(\alpha/2; n-k-1)$, so it give result for value of t table is 0025;69. Refer to “value distribution guide t table”, it give result for t table value is 1,99. The background of consideration in t-test testing is: H_0 rejected and H_1 accepted if Sig. value < 0.05 the meaning is there a significant effect between the independent variables on dependent variable. Otherwise, H_0 accepted and H_1 rejected if Sig. value > 0.05. H_0 accepted and H_1 rejected, if the t table cumulative value < t table or if Sig. value > 0.05. Therefore, H_0 rejected and H_1 accepted if H_0 accepted and H_1 rejected, if the t table cumulative value > t table or if Sig. value < 0.05. Then, mediational hypothesis testing can carry out with two ways, are causal step and product of coefficient strategy, refer to Figure 3 (AmirKhali, 2013; Fritz et al., 2012; Karazsia et al., 2013; Kenny & Judd, 2014; Memon et al., 2018; Turnes & Ernst, 2015).

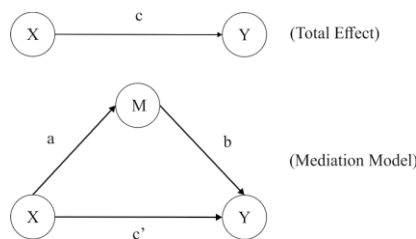

Figure 3. The strategy of the model of the causal steps

The essential point of causal step in mediational hypothesis testing is there was any interaction between effect mediator independent variable and mediator effect dependent variable (MacKinnon et al., 2012; Thoemmes et al., 2010). If the coefficient of c' is insignificant ($c' = 0$), the perfect or complete mediation condition is consisting. But, ~~if~~ c' coefficient decreases but ~~it~~ remain significant ($c' \neq 0$), it will be concluded as consist (MacKinnon et al., 2002; Nitzl et al., 2016; Preacher & Hayes, 2004). Meanwhile, mediational hypothesis testing by using the product of coefficient strategy based on significant indirect effects “**ab**” testing. Significant testing is using the resampling method, bootstrapping (Afanadorac et al., 2013; Carrión et al., 2017; Chernick, 2011; Cheung & Lau, 2007; Ghozali & Latan, 2015b). The bootstrapping method developed by Andrew F. Hayes (Preacher & Hayes, 2008) is considered more effective because

- Formatted: Font: Garamond, 12 pt, Greek, Expanded by 0,2 pt
- Formatted: Indent: Left: 0 cm, Hanging: 0,48 cm, Bulleted + Level: 1 + Aligned at: 0,36 cm + Indent at: 0,99 cm
- Formatted: Font: Garamond, 12 pt, Greek
- Formatted: Greek, Expanded by 0,2 pt
- Formatted: Font: Garamond, 12 pt, Greek, Expanded by 0,2 pt
- Formatted: Font: Garamond, 12 pt, Greek
- Formatted: Greek, Expanded by 0,2 pt
- Formatted: Font: Garamond, 12 pt, Greek, Expanded by 0,2 pt
- Formatted: Font: Garamond, 12 pt, Greek
- Formatted: Font: Garamond, 12 pt, Greek, Expanded by 0,2 pt

Formatted: Not Highlight

there is no normality assumption needed and large sample as is Sobel Test who popularized by Baron dan Kenny (1986).

D. Test of Validity and Reliability

Validity test validity is a test of the accuracy or accuracy of a measuring instrument in measuring what is being measured. The validity test aims to assess whether a set of measuring instruments correctly measures what should be measured. D. Test of Validity and Reliability

Formatted: Font: Not Bold

Formatted: Indent: First line: 0 cm

III. RESULT AND DISCUSSION

Formatted: No bullets or numbering

A. Model Measurement Evaluation (Model Outer)

Test of Validity and Reliability. Validity test validity is a test of the accuracy or accuracy of a measuring instrument in measuring what is being measured. The validity test aims to assess whether a set of measuring instruments correctly measures what should be measured. (Ghozali & Latan, 2015a; Hair et al., 2012, 2013; Hair et al., 2017). The reliabilities of the research questionnaire has made shall be observed. Reliability is how far the scale would give consistent result if the instrument used continuously and give the same measurable results. (Ali & Bhaskar, 2016; Malhotra, 2017; Singh & Masuku, 2014; Ursachi et al., 2015; Valentini & Damasio, 2016). In this research, the reliability test for each variable measured by Cronbach's alpha. There are two reasons for using Cronbach's alpha test (Bryman & Bell, 2007; Taber, 2016; Ursachi et al., 2015): (1) this method is a most using reliability test method; and (2) by using Cronbach's alpha inconsistent indicator will be detected. Eisingerich dan Rubera (2010) stated that the minimum reliability value of Cronbach's Alpha minimum is 0.70 (≥ 0.7), and it contributes to internal consistency.

Averages variants and composite reliability that suggested is more than minimum reliability degree value (Sarstedt et al., 2017; Turnes & Ernst, 2015; Ullman & Bentler, 2013). Reliability degree values of Cronbach's Alpha are (Ghozali & Latan, 2015b; Hair et al., 2016; Taber, 2016; Ullman & Bentler, 2013; Vinzi et al., 2010): less reliable (0.0 – 0.20), quite reliable (>0.20 – 0.40), adequate reliable (>0.40 – 0.60), reliable (>0.60 – 0.80), and well reliable (>0.80 – 1,00). Another reliability testing can be carried out by considering to composite reliability (CR) value from an indicator block that measures the construct (Ursachi et al., 2015; Valentini & Damasio, 2016). CR result will show the satisfied value if more than 0.7.

There were six variables with 24 indicators tested in this research validity and reliability tests. Those are Economic variable (6 indicators namely, informal labour, wood productivity, farmers' income, bargaining position of middleman, market price incentives for community timber, and sawn wood market), Social & Culture variable (4 indicators namely, increased value-added of wood, employment rate, forest farmer's household poverty, and farming socialization), Ecology variable (3 indicators namely, land-use to built-up land, conservation of degraded land, and land-use efficiency) and Legal & Institutional variable (4 indicators namely, microfinance institutions, the number of forestry extension agents, agriculture and forestry extension program, and government extension organization), Accessibility & Technology variable (4 indicators namely, access road to the public service centre, access to timber market information, postharvest wood processing, and logging method) and Sustainability of Community Forests variable (3 indicators namely, regional economic growth, regional poverty, and welfare of the forest community).

Formatted: Font: Not Italic, Not Highlight

Formatted: Font: Not Italic, Highlight

Commented [A13]: Please explain all indicator tested in this study!

Commented [A14R13]: We have completed, yellow highlight

Formatted: Font: Not Italic, Highlight

Commented [A15]: You have not yet responded to the comment (A3). Please be add all the indicator name not just number of indicators. Methodology should be very clear to all the readers!!!

Commented [A16R15]: We have completed, yellow highlight

Formatted: Indent: First line: 0,36 cm

IV-III. RESULT AND DISCUSSION

As explained above, the measurement evaluation model uses 24 indicators. These indicators are obtained from literature studies such as research journals, forest regulations, center for international forestry research (CIFOR), sustainable production forest management (PHPL), central statistical agency (BPS), and other standard guidelines and based on field observations in accordance with the principles of sustainable development.

A. Model Measurement Evaluation (Model Outer)

A. Model Measurement Evaluation (Model Outer)

Determination of indicators is based on the participation of forest farmer groups in maintaining sustainable economic, social, environment, and institutions. The criteria for determining the indicators must meet the criteria of (a) Sensitive, which has a high level of sensitivity when used to measure so that it can minimize the number of indicators needed, (b) Specific, which has clear coverage so as to prevent overlapping, (c) Relevant, which is related to the object to be measured.

Determination of economic indicators to assess forest management activities by forest farmer groups such as family income sources, farmers' ability to provide for family needs, farming activities and others. The social and cultural factors considered include welfare, poverty conditions, and land ownership. Ecological factors focus on indicators of environmental concern, land conversion, and productive land use. Institutional and legal factors include access to information, the role of extension workers, forest farmer groups. The accessibility & technology factors were measured through indicators of the use of agricultural technology, market access, and post-harvest processing.

An indicator is a variable that is used to measure a change, either directly or indirectly, to a condition. Something deserves to be used as an indicator when it meets the following criteria: (1) Valid, which can be used to measure the object to be assessed. (2) Reliable, ie can be trusted. That is, being able to show consistent results when repeated measurements are made both now and in the future.

Table 1 shows that Cronbach alpha testing result and CR that have the smallest value were, was [ACT] Accessibility & Technology dimension value 0.895 and [SOC] Social & Culture 0.910, or both values is more than 0.7. Therefore, it did not find reliability issues or un-dimensionality on the former method. There is six variable with 21-24 indicators tested in this research validity and reliability tests. Those are Economic variable (6 indicators), Social & Culture variable (4 indicators), Ecology variable (3 indicators) and Legal & Institutional variable (4 indicators), Accessibility & Technology variable (4 indicators) and Sustainability of Community Forests variable (3 indicators).

The validity test result shows that all indicator is valid due to the average variance extracted (AVE) value which is more than 0.5 (>0.5). Validity test result with Cronbach alpha shows that all indicator is reliable due to it has alpha more than 0.7. To get the Goodness of Fit (GoF) value on PLS-SEM, it shall be formulated by $\sqrt{AVE * R^2}$ (Tenenhaus et al., 2005; Valentini & Damasio, 2016). Test Good results of Validity and Reliability Test good results shows that construct method is robust (strong) (Cham et al., 2012; Maslowsky et al., 2015; Ursachi et al., 2015) and hypothesis Test can be carried out.

Table 1. Reliability and validation test on the dimensions of community forest sustainability

Variable	Reliability	Validation	GoF	Desc.
----------	-------------	------------	-----	-------

Formatted: Highlight

Formatted: Indent: First line: 0 cm

Formatted: Highlight

Formatted: Highlight

Commented [A17]: What does this mean? Please use clear sentence

Commented [A18]: 21 or 24?

	Cronbach's Alpha	Composite Reliability (CR)	Average Variance Extracted (AVE)		
[ECO] Economic	0.960	0.968	0.833	NA	Good (fit)
[SOC] Social & Culture	0.910	0.937	0.789	0.806	Good (fit)
[EGY] Ecology	0.933	0.957	0.882	0.898	Good (fit)
[LIT] Legal & Institutional	0.955	0.967	0.881	0.810	Good (fit)
[ACT] Accessibility & Technology	0.895	0.927	0.761	0.796	Good (fit)
[SCF] Sustainability of Community Forests	0.944	0.964	0.899	0.916	Good (fit)

Remarks:

- [ECO1] informal labour, [ECO2] wood productivity, [ECO3] farmers' income, [ECO4] bargaining position of middleman, [ECO5] market price incentives for community timber, [ECO6] sawn wood market.
- [SOC1] increased value-added of wood, [SOC2] employment rate, [SOC3] forest farmer's household poverty, [SOC4] farming socialization.
- [EGY1] land-use to built-up land, [EGY2] conservation of degraded land, [EGY3] land-use efficiency.
- [LIT1] microfinance institutions, [LIT2] the number of forestry extension agents, [LIT3] agriculture and forestry extension program, and [LIT4] government extension organization.
- [ACT1] access road to the public service centre, [ACT2] access to timber market information, [ACT3] postharvest wood processing, [ACT4] logging method.
- [SCF1] regional economic growth, [SCF2] regional poverty, [SCF3] welfare of the forest community.

Formatted: Font: 11 pt

Commented [A19]: How to determine and measures these indicators?

It is better if you explain first those indicators before you analyse them using PLS-SEM. So that, readers will have more understanding on the results and discussion on how one indicator or variable affect other indicator/variables, rather than the mechanistic process from PLS-SEM that is vastly explain in this manuscript!

Commented [A20R19]: We have explained it, yellow highlight

Commented [A21]: You also did not give respond and revision to the comment (A7). Please pay attention to that comment!!!

Commented [A22R21]: We hope the above explanation has paid off.

Formatted: Font: Garamond, 11 pt

Formatted: Font: Garamond, 11 pt

Formatted: Font: 11 pt

Formatted: Font: Garamond

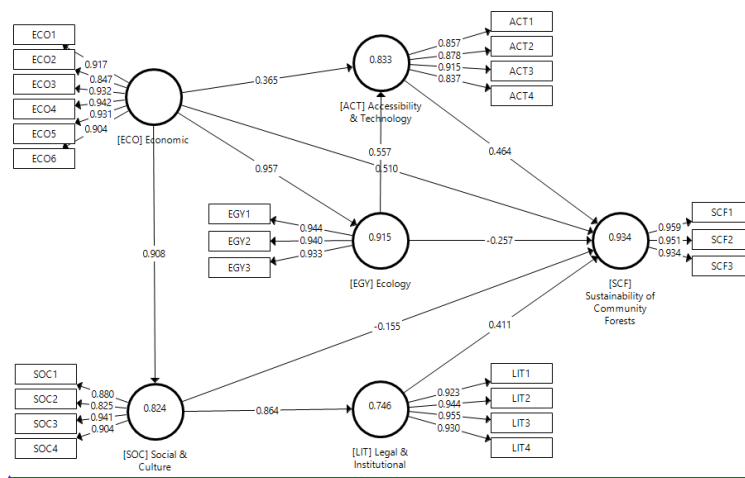
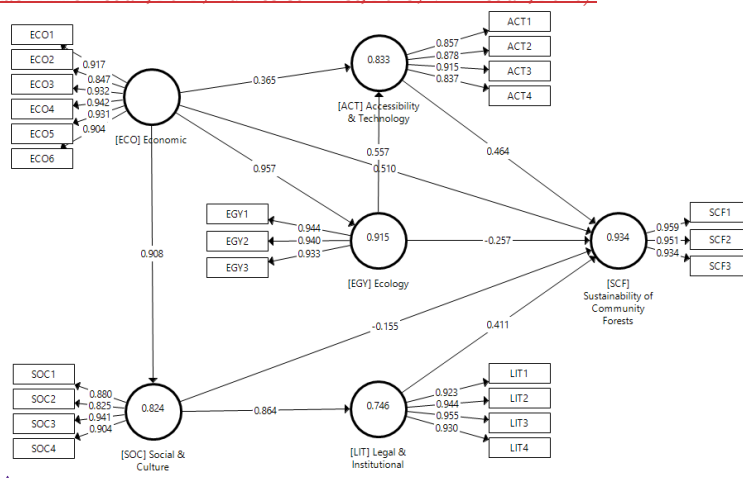

Figure 4. Structural path diagram for the sustainability of community forests, the results of the PLS-SEM algorithm

Figure 4 shows that Economic (ECO) Constructed variable measured by 6 (six) indicators (instrument), they are ECO1, ECO2, ECO3, ECO4, ECO5 and ECO6. Constructed (latent variable) Social & Culture (SOC) measure by 4 (four) indicators, they are SOC1, SOC2, SOC3, and SOC4. Constructed Ecology (EGY) measured by 3 (three) indicators, they are EGY1, EGY2

and EGY3. Constructed legal and institutional (LIT) measured by four indicators, they are LIT1, LIT2, LIT3, and LIT4. Constructed accessibility and technology (ACT) measured by 4 (four) indicators; they are ACT1, ACT2, ACT3, and ACT4. Constructed the main target is the sustainability of community forests (SCF) measured by 3 (three) indicators; they are SCF1, SCF2, and SCF3. The arrow between the indicator and the latent construction shows that the study uses the correct reflective indicator to measure perception. Object relations symbolized with an arrow between constructs. Figure 4 shows that the loading factor with the smallest amount is 0.825 (indicator SOC2) or more than 0.5. It means that other applicable indicators in this research are valid or fulfilled the convergent validity requirement (Cham et al., 2012; Dawson, 2014; MacKinnon et al., 2012; Turnes & Ernst, 2015; Vinzi et al., 2010).



Formatted: Font: Garamond

Figure 4. Structural path diagram for the sustainability of community forests, the results of the PLS-SEM algorithm

Connectivity Effect Path Across Variable for Forest Community Sustainability. Based on connection testing to the across variables path that there is a relation between two variables that are not significant, namely the SOC Variable Effect to EGY. This non-signification indicated by the p-value of 0.254 or exceeds above the recommended p-value of 0.05. Generally, the interpretation of p-value based on the parameter value must be smaller than the threshold value, which is 0.05. Where, if the value of $p < 0.05$, it is considered that a relation between variables is significant. On the contrary, it is not significant if the value of $p > 0.05$. In Table 2 it shows that the relation of variables has very significant connectivity ($p\text{-value} = 0$) are ACT to SCF, ECO to EGY, ECO to SOC, and SOC to LIT.

The original sample estimate value is positive, that is 0.908, which shows that the direction of connectivity between ECO and SCF is positive. The T-statistic value, which is not significant, is found in the relation between SOC and EGY variables 1.143. The value of the relationship between other variables is significant. The lowest significant t-statistic value is 1.99. Path coefficient validation test for each direct effect path is the same as for the regression, using the t value of the t-test, testing the variable regression coefficient is partially standardized (Ghozali & Latan, 2015b; Hair et al., 2014).

Table 2. Test the path coefficient: sample, mean, STDEV, t-statistic, p-values

No	Variable	Original Sample (O)	Sample Mean (M)	Standard Error (STERR)	T-Statistics (O/STERR)	P-values
1	[ACT] → [SCF]	0.463	0.467	0.100	4.622	0
2	[EGY] → [ACT]	0.557	0.544	0.191	2.925	0.004
3	[EGY] → [SCF]	-0.256	-0.254	0.129	1.995	0.047
4	[ECO] → [ACT]	0.365	0.377	0.179	2.036	0.042
5	[ECO] → [EGY]	0.835	0.833	0.108	7.771	0
6	[ECO] → [SCF]	0.509	0.489	0.194	2.619	0.009
7	[ECO] → [SOC]	0.908	0.909	0.030	30.022	0
8	[LIT] → [SCF]	0.411	0.428	0.170	2.412	0.016
9	[SOC] → [EGY]	0.133	0.137	0.117	1.143	0.254
10	[SOC] → [SCF]	-0.154	-0.158	0.059	2.614	0.009
11	[SOC] → [LIT]	0.864	0.865	0.043	20.291	0

Based on trimming theory, non-significant pathways discarded, in this research, the SOC variable to EGY, so that a model that is supported (confirmed) by empirical data is obtained. Discriminant validity reflexive indicators can be seen in the cross-loading between the indicator and its construct (Sarstedt et al., 2017; Ullman & Bentler, 2013; Vinzi et al., 2010). From Table 2 it shows the correlation construct with its indicator (bold) is higher than the correlation indicator innovation with other constructs. This shows that the latent construct predicts the indicators in each block itself better than the indicators in other blocks. Overall, the construct has high discriminant validity. Based on the weight value, most indicators show less than 0.1; then it can be concluded that all indicators on each latent contract can still be used in modelling.

Table 2. Test the path coefficient sample, mean, STDEV, t statistic, p values

No	Variable	Original Sample (O)	Sample Mean (M)	Standard Error (STERR)	T-Statistics (O/STERR)	P-values
1	[ACT] → [SCF]	0.463	0.467	0.100	4.622	0
2	[EGY] → [ACT]	0.557	0.544	0.191	2.925	0.004
3	[EGY] → [SCF]	-0.256	-0.254	0.129	1.995	0.047
4	[ECO] → [ACT]	0.365	0.377	0.179	2.036	0.042
5	[ECO] → [EGY]	0.835	0.833	0.108	7.771	0
6	[ECO] → [SCF]	0.509	0.489	0.194	2.619	0.009
7	[ECO] → [SOC]	0.908	0.909	0.030	30.022	0
8	[LIT] → [SCF]	0.411	0.428	0.170	2.412	0.016
9	[SOC] → [EGY]	0.133	0.137	0.117	1.143	0.254
10	[SOC] → [SCF]	-0.154	-0.158	0.059	2.614	0.009
11	[SOC] → [LIT]	0.864	0.865	0.043	20.291	0

B. Structural Model Testing (Inner Model)

Coefficient of Determination. Structural model testing used to evaluate the estimation parameter coefficient path value and its significant degree. The first test can be done by calculates R-Square Value which is a goodness-fit model and next test is done by assessing the construct significant

effect and consider to coefficient parameter value and significant t statistic value (Maslowsky et al., 2015; Sarstedt et al., 2017; Turnes & Ernst, 2015; Vinzi et al., 2010).

The coefficient of determination with r^2 symbol is the proportion of variability in a calculated data based on a statistical model. The following definition states that r^2 is the ratio of the variability of values made by the model to the variability of the original data values. In general, r^2 is used as information about the suitability of a model. In regression, r^2 is used as a measurement of how well the regression lines approach the original data values created by the model. If r^2 is equal to 1, then the number shows the regression line matches the data perfectly (Ghozali & Latan, 2015b; Hair et al., 2014).

Another interpretation is that r^2 is defined as the proportion of variation of responses explained by the regressor (independent variable/X) in the model. Thus, if $r^2 = 1$ will mean that the corresponding model explains all the variability in the Y variable. If $r^2 = 0$ will mean that there is no relationship between the regressor (X) and the Y variable. In the case for example if $r^2 = 0.833$ has the meaning that 83.30% of the variation of the endogenous variable ACT (dependent variable/response) can be explained by the variable X (independent variable/explanatory); while the remaining 16.70 is influenced by unknown variables or inherent variability. Table 3 shows that the endogenous variable IJT has a coefficient of determination value, $r^2 = 0.746$. There was a change in the coefficient of determination after trimming, but it was exceedingly small. Based on the coefficient of total determination (trimming results), it was found that the model can explain the information contained in the data, amounting to 80.90%. This figure is exceptionally large, so it is worth further interpretation. After trimming the SOC variable path to the EGY variable p-value above 0.05, on the other hand, the exogenous & endogenous variable values of p are below 0.05 ($p < 0.05$) or significant category, where the largest value is 0.045, i.e. there is a variable path EGY to SCE.

Table 3. The coefficient of determination (r^2) before (original) and after trimming

Endogenous variable (D_{ij})	R-Square		change r^2	Total r^2
	original	trimming		
Accessibility & Technology [ACT]	0.833	0.833	fixed	0.694
Ecology [EGY]	0.948	0.945	down	0.837
Sustainability of Community Forests [SCL]	0.933	0.934	up	0.872
Legal & Institutional [IJT]	0.746	0.746	fixed	0.557
Social & Culture [SOC]	0.824	0.824	fixed	0.670
			$R_n^2 = 1 - P_1^2 - P_2^2 - \dots - P_q^2$	0.809

Table 4. Direct effect, indirect effect, and the total effect

Variable	Effect Direct	Effect Indirect	Total Effect	
			Value	Average
Ecology	0.334**	0.561	0.895	0.895
Social & Culture	0.047**	0.778	0.825	0.827
Economic	0.378**	0.477	0.855	0.862
Legal & Institutional	0.582**	=	0.582	0.597
Accessibility & Technology	0.408**	=	0.408	0.393

** significant at α level = 0.05

The effect of dimensional variables. In the structural path analysis, the path scheme discussed the basic path connecting the origin of the dimension variable to the SCF variable as the destination path directly or through other variables first. In analyzing the structural path, the path

identified have direct effects, indirect effects and total effects (MacKinnon et al., 2012; Maslowsky et al., 2015; Turnes & Ernst, 2015).

In general, the ECO dimension variable directly reflects positively to SOC, EGY, ACT, and SCF. If there is an improvement in the sustainability of the ECO dimension, the conditions in the dimensions of SOC, EGY, ACT and SCF will also improve, and vice versa. From the estimation results, it shows the Variable Effect dimension of ECO to SOC has a path coefficient of 0.908 or the magnitude of the ECO effect on SOC of 90.80 %. Where the effect is significant at the value of $t = 28,501$ ($> t$ table = 1.99). Variable ECO to EGY has a significant effect of 0.957 or 95.70 %. Likewise, with the ECO variable for ACT and SCF each of 0.365 or 36.50 % and 0.510 or 51 %. Overall, calculation results show a probability value < 0.05 , there is enough data to reject H_0 and accept H_1 . That is, there is a linear relationship between the ECO variable with SOC, EGY, and ACT.

Figure 4 the measurement results of the effects of each variable on the sustainability dimension to each of the lever indicators. The overall calculation results show a significant-good probability value (< 0.05) and T Statistics ($> t$ table = 1.99). All sustainability dimension variables show a positive effect on the lever indicator. That indicated by the positive estimation value. The lowest estimation value is the effect of the SOC dimension variable of the labour absorption rate [SOC2], the path coefficient of 0.825 or 82.50 %.

Table 3. The coefficient of determination (r^2) before (original) and after trimming

Endogenous variable (P_{ep})	R Square		change r^2	Total r^2
	original	trimming		
Accessibility & Technology [ACT]	0.833	0.833	fixed	0.694
Ecology [EGY]	0.918	0.915	down	0.837
Sustainability of Community Forests [SCF]	0.933	0.934	up	0.872
Legal & Institutional [LIT]	0.746	0.746	fixed	0.557
Social & Culture [SOC]	0.824	0.824	fixed	0.679
			$R_m^2 = 1 - P_{e1}^2 P_{e2}^2 \dots P_{ep}^2$	= 0.809

Table 4. Direct effect, indirect effect, and the total effect

Variable	Effect Direct	Effect Indirect	Total Effect	
			Value	Average
Ecology	0.334**	0.561	0.895	0.895
Social & Culture	0.047 *	0.778	0.825	0.827
Economic	0.378**	0.477	0.855	0.862
Legal & Institutional	0.582**	=	0.582	0.597
Accessibility & Technology	0.408**	=	0.408	0.393

** significant at α level = 0.05

In general, the ECO dimension variable directly reflects positively to SOC, EGY, ACT, and SCF. If there is an improvement in the sustainability of the ECO dimension, the conditions in the dimensions of SOC, EGY, ACT and SCF will also improve, and vice versa. From the estimation results, it shows the Variable Effect dimension of ECO to SOC has a path coefficient of 0.908 or the magnitude of the ECO effect on SOC of 90.80 %. Where the effect is significant at the value of $t = 28,501$ ($> t$ table = 1.99). Variable ECO to EGY has a significant effect of 0.957 or 95.70 %. Likewise, with the ECO variable for ACT and SCF each of 0.365 or 36.50 % and 0.510 or 51 %. Overall, calculation results show a probability value < 0.05 , there is enough data to reject H_0 and accept H_1 . That is, there is a linear relationship between the ECO variable with SOC, EGY, and ACT.

Formatted: Not Highlight

Formatted: Highlight

Figure 4 the measurement results of the effects of each variable on the sustainability dimension to each of the lever indicators. The overall calculation results show a significant good probability value (<0.05) and T Statistics ($> t$ table = 1.99). All sustainability dimension variables show a positive effect on the lever indicator. That indicated by the positive estimation value. The lowest estimation value is the effect of the SOC dimension variable of the labour absorption rate (SOC2), the path coefficient of 0.825 or 82.50 %.

Indicators become a lever factor in the ECO dimension are not attracting workers in the informal forestry sector from farming families (ECO1), low monthly farmer income (ECO3), low bargaining power of farmers towards forest product (ECO4, ECO6), and low productivity of timber farmer (ECO2). Economic dimension (ECO) levers are related to Social & Culture (SOC) issues such as poverty (SOC3). Here it can be explained that the direct effect received by the poverty indicator from each increase of indicators in the ECO dimension is 0.941. That is, there is a significant direct influence on indicators in the economic dimension such as high informal labour, wood productivity, farmers' income, and bargaining position of middleman, all of which affect poverty indicators in the social dimension. According to Sukwika et al. (2018), easy market access and the added value of timber can suppress the bargaining power of the middleman hence reducing poverty.

The direct effect generated through the ECO to SOC which has a direct effect of 0.908 (Figure 5).

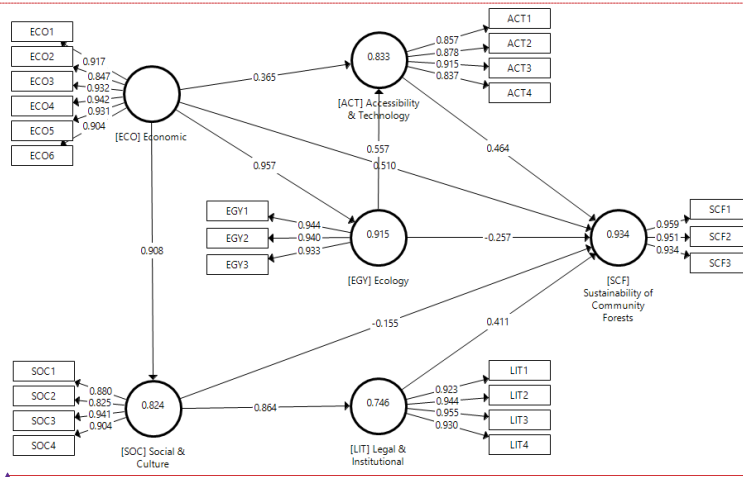

Figure 5. Structural path diagram for the sustainability of community forests, the results of the PLS-SEM algorithm

Income (ECO3) is related to the availability of employment, especially for informal workers (ECO1), business conditions (ECO2, ECO5), and other economic factors. Provision of employment opportunities is needed by all parties so that the community has a better income to meet the family's living needs. Thus, as conditions improve in the Economic dimension, it can have a positive effect on reducing the problem of poverty (SOC3) and to encourage the participation of farmers (SOC1) in achieving prosperity through community forest activities. Improving economic conditions (ECO) have a positive effect on Ecology (EGY), especially the behaviour of farmers in using land more productively both for cultivated land (EGY2) and their land-use efficiency (EGY3) in a direction that can get economic values. Economic conditions

Commented [A23]: Figure 5?

Commented [A24R23]: We've fixed it

Formatted: Font: Garamond

Commented [A25]: Figure 5?

Please check the order of all Figures!!!

Commented [A26R25]: We've fixed it

[ECO] positively affect farmers' efforts to increase the added-value of timber through postharvest timber processing (ACT3) and study of standard logging techniques (ACT4) and are supported by encouragement to gain access to timber market information (ACT2).

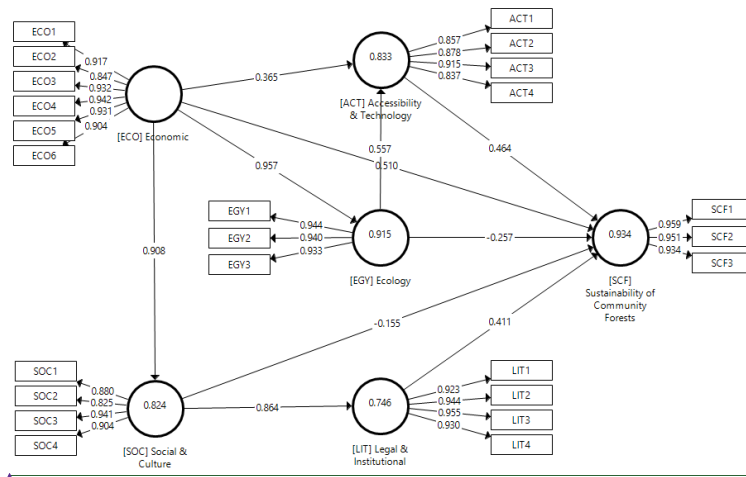

Formatted: Font: Garamond

Figure 5. Structural path diagram for the sustainability of community forests, the results of the PLS-SEM algorithm

Commented [A27]: Figure 5?

Please check the order of all Figures!!!

Commented [A28R27]: We've fixed it

To find out whether there is perfect or partial mediation can be showed if the coefficient c is statistically significant. Perfect/complete mediation occurs when independent variables do not influence the dependent when the mediator is controlled (Fritz et al., 2012; Hayes & Rockwood, 2016; Karazsia et al., 2013; Kenny & Judd, 2014; Nitzl et al., 2016). If the coefficient c is statistically significant, and there is also a significant mediation, then it is called partial mediation. The causal step strategy itself has a weakness/not powerful enough to detect mediation; the requirements must comply where the relationship X to Y must be significant and become insignificant when there is perfect mediation (direct effect = 0), whereas there are many cases where mediation significantly but the relationship X to Y is not significant (MacKinnon et al., 2012; Sarstedt et al., 2017; Thoemmes et al., 2010; Turnes & Ernst, 2015; Ullman & Bentler, 2013).

Besides, it is also necessary to see whether the mediation model is consistent or inconsistent. An inconsistent model is a model where there is at least one mediating effect that has a different sign from another mediation effect or a direct effect. Or in other words if c (direct effect) is the opposite of ab (indirect effect). In this case, the mediator acts as a suppressor variable. This inconsistent model is the opposite of a consistent model in which direct and indirect effects have the same sign. It shows that there is an inconsistent mediation effect (suppression), but the first criterion (the X to Y relationship is not significant). For example, X (predictor), M (mediator) and Y (criterion). In the mediation model, the direct effect of the predictor on the criterion is negative, and the indirect effect of the predictor on the error mediated by the mediator is positive (Hayes & Scharkow, 2013; Turnes & Ernst, 2015; Yzerbyt et al., 2018).

Variable of the ECO (predictor) dimension has a direct relationship to SCF (criterion) will has a positive path coefficient of 0.378 or 37 percent with a probability value <0.05 , then there is enough data to reject H_0 and accept H_1 . If using the mediational hypothesis test approach with

casual steps technique, then to calculate the direct effect the following formula is used, see Figure 5: (1) variable effect independent / predictor of the mediator ($X \rightarrow M$) is $a = \text{ECO ACT} + (\text{ECO EGY} * \text{EGY ACT}) + (\text{ECO SOC} * \text{SOC LIT}) = 0.365 + (0.957 \times 0.557) + (0.863 \times 0.451) = 1.287$; (2) variable effect mediator on dependent/criterion ($M \rightarrow Y$) is $b = \text{ACT SCF} + \text{EGY SCF} + \text{LIT SCF} = 0.448 + (-0.292) + 0.451 = 0.607$; (3) variable effect independent/predictor of dependent/criterion ($X \rightarrow Y$) is $c' = \text{ECO SCF} = 0.378$. Indirect effect ECO to SCF in this path analysis has 4 (four) paths, they are:

- (1) Indirect effect variable dimension ECO (predictor) (36,50%) to SCF (criterion) is ACT (mediator) with track coefficient 0.448. It means increasing of SCF have to be done by increasing economic and followed by an effort to make easier ACT to forest farmers (indirect effect = 44,80%).
- (2) Indirect effect of ECO to SCF through EGY mediation which has path coefficient value -0.292. It explained that the more of ECO acceleration by one per cent, the impact on SCF decreases by 29,20%, and vice versa.
- (3) Indirect effect of ECO to SCF (45,10%) through 2 serial mediator SOC (90,70%) then LIT (86,30%).
- (4) Indirect effect of ECO to SCF (44,80%) through 2 serial mediator is EGY (95,70%) then ACT (75,70%).

The total effect captures the direct effect along the path and the indirect effect path (path) of the circuit associated with the path. The total effect (TE) captures the direct effect along the path and the indirect effect path (path) of the circuit associated with the path (Ghozali & Latan, 2015b; Hair et al., 2014; Hayes & Scharkow, 2013; Kenny & Judd, 2014; MacKinnon et al., 2012; Turnes & Ernst, 2015). The total ECO effect on SCF is 0.855, it means that each increasing of score from the Economic dimension by 100% will increase the SCF score by 85,5%. Value of R^2 0.849 means the number of variants can be explained by the Economic dimension of the SCF variation is equal to 84,9% or equal with 37,1 [$= \sqrt{(1-0.849)}$] explained by the other variables outside the model and error. The total effect value of the ECO dimensions on SCF is obtained by calculating as follows: $TE = \text{Path 1 (ECO SCF)} + \text{Path 2 (ECO ACT} * \text{ACT SCF)} + \text{Path 3 (ECO EGY} * \text{EGY SCF)} + \text{Path 4 (ECO SOC} * \text{SOC LIT} * \text{LIT SCF)} + \text{Path 5 (ECO EGY} * \text{EGY ACT} * \text{ACT SCF)} = 0.378 + (0.365 \times 0.448) + (0.957 \times -0.292) + (0.907 \times 0.863 \times 0.451) + (0.957 \times 0.557 \times 0.448) = 0.378 + (0.164) + (-0.279) + (0.353) + (0.239) = 0.855$.

The result of the direct effect of the mediation model of predictor X to the criterion Y (c') is significant where the probability value $0.021 < 0.05$, and there is a significant indirect mediator M effect, it can be interpreted as mediation that occurs partial mediation (Kenny, 2008; Kenny & Judd, 2014). The mediation effect in the model and the coefficient c' significant, which means there is an effect and when viewed from the value of the direct effect (coefficient c') X of Y is 0.510 (positive) or not opposed with indirect effect (coefficient ab) is 1.002 (positive), it can be said that the mediation model in this study is consistent and directly proportional. So they decide to reject H_0 and accept H_1 , meaning is there a significant effect between the independent variables on the dependent variable.

C. Economic Dimension Modeling

The Economic dimension model is formed based on the results of the analysis of valid indicators used in the measurement and variable-latent models that significantly reflect the structural model (Cham et al., 2012; Ursachi et al., 2015; Yzerbyt et al., 2018). From the analysis results obtained an evaluation (validation) from the Measurement model that the 24 valid indicators in Measurement for each latent construct are shown by loading values for all indicators greater than 0.7 so that all indicators can be used in forming the SCF model.

Formatted: Justified

Based on [Figure 6](#), in this study the SCF model that consists of five structural models and six Measurement models as follows : (1) Model of structural for latent variable SOC to LIT : $\eta_{LIT} = 0.864 \xi_{SOC}$; (2) Model of structural for latent variable ECO to SOC: $\eta_{SOC} = 0.908 \xi_{ECO}$; (3) Model of structural for latent variable ECO to EGY: $\eta_{EGY} = 0.957 \xi_{ECO}$; (4) Model of structural for latent variable ECO and EGY to ACT: $\eta_{ACT} = 0.365 \xi_{ECO} + 0.557 \xi_{EGY}$; (5) Model of structural for latent variable ACT, ECO, EGY, and LIT to SCF: $\eta_{SCF} = 0.464 \xi_{ACT} + 0.510 \xi_{ECO} - 0.257 \xi_{EGY} + 0.411 \xi_{LIT}$. Model of Construct Measurement ECO, ACT, EGY, SOC, LIT, and SCF are:

$$\begin{bmatrix} ECO1 \\ ECO2 \\ ECO3 \\ ECO4 \\ ECO5 \\ ECO6 \end{bmatrix} = \begin{bmatrix} 0.917 \\ 0.847 \\ 0.932 \\ 0.942 \\ 0.931 \\ 0.905 \end{bmatrix} \eta_{ECO}$$

$$\begin{bmatrix} ACT1 \\ ACT2 \\ ACT3 \\ ACT4 \end{bmatrix} = \begin{bmatrix} 0.857 \\ 0.878 \\ 0.915 \\ 0.837 \end{bmatrix} \eta_{ACT}$$

$$\begin{bmatrix} EGY1 \\ EGY2 \\ EGY3 \end{bmatrix} = \begin{bmatrix} 0.944 \\ 0.940 \\ 0.933 \end{bmatrix} \eta_{EGY}$$

(1) Measurement (ECO) (2) Measurement (ACT) (3) Measurement (EGY)

$$\begin{bmatrix} SOC1 \\ SOC2 \\ SOC3 \\ SOC4 \end{bmatrix} = \begin{bmatrix} 0.878 \\ 0.826 \\ 0.941 \\ 0.904 \end{bmatrix} \eta_{SOC}$$

$$\begin{bmatrix} LIT1 \\ LIT2 \\ LIT3 \\ LIT4 \end{bmatrix} = \begin{bmatrix} 0.923 \\ 0.944 \\ 0.955 \\ 0.930 \end{bmatrix} \eta_{LIT}$$

$$\begin{bmatrix} SCF1 \\ SCF2 \\ SCF3 \end{bmatrix} = \begin{bmatrix} 0.959 \\ 0.951 \\ 0.933 \end{bmatrix} \eta_{SCF}$$

(4) Measurement (SOC) (5) Measurement (LIT) (6) Measurement (SCF)

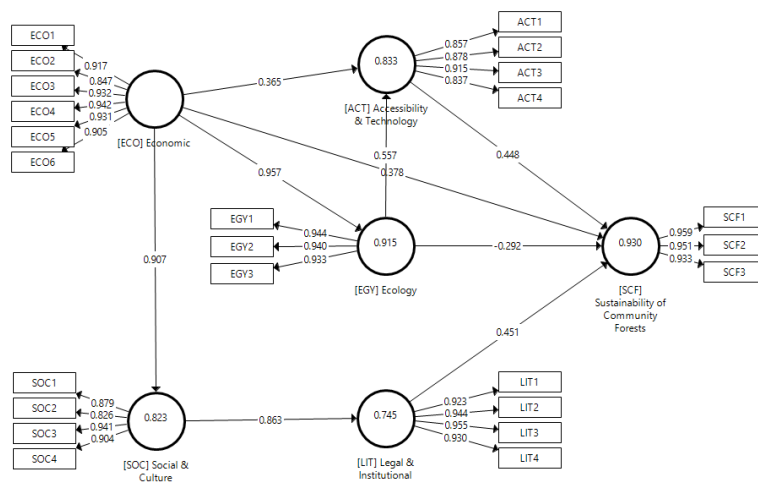

[Figure 6](#). Structural path diagram of economic to the sustainability of community forests, the results of the trimming of PLS-SEM algorithm

The trend of similar findings in the forestry sector regarding the relationship between dependent and independent variables is evidenced by [Tadesse dan Teketay \(2020\)](#) through The multiple linear regression models which revealed that independent variables derived from demographic, socio-economic, bio-physical, and institutional factors significantly affected the dependent variables, namely the dependencies of local communities on plantation forests. In line

Formatted: Font: Garamond

with that, Sukwika et al. (2016) also found a direct effect on developing the region's timber-based management and processing through an integrated system that involves community (society) and business, i.e., increased value-added of wood, information of wood market, and institutional strengthening of forest farmer groups. Subsequently, Van Gossum et al. (2011) and Sukwika et al. (2020) agreed that there are four key actors who are the most dominant having a direct effect in the community-forest action arena, i.e. farmer landowners, farm labors, lumbermens and middlemen.

D. Social Dimension Modeling

In this study, the SOC dimension model was formed based on the results of the analysis of valid indicators used in the measurement model and the latent variable that significantly reflected the structural model. From the analysis results obtained evaluation results (Validation) from the measurement model that the 11 indicators are valid in the measurement of each latent construct indicated by the loading value for all indicators greater than 0.7, so all indicators can be used in forming the SCF model. Thus, based on Figure 6, in this study, the Sustainability of Community Forests model that can be formed consists of two structural models and three Measurement models as follows (1) Model of Structural for effect latent variable SOC to LIT is: $\eta_{LIT} = 0.864 \xi_{SOC}$; (2) Model of structural for latent variable SOC and LIT to SCF is $\eta_{SCF} = 0.047 \xi_{SOC} + 0.900 \xi_{LIT}$ (not applicable). Model of Construct Measurement SOC, LIT, and SCF is:

$$\begin{bmatrix} SOC1 \\ SOC2 \\ SOC3 \\ SOC4 \end{bmatrix} = \begin{bmatrix} 0.882 \\ 0.824 \\ 0.941 \\ 0.903 \end{bmatrix} \eta_{SOC} \quad \begin{bmatrix} LIT1 \\ LIT2 \\ LIT3 \\ LIT4 \end{bmatrix} = \begin{bmatrix} 0.923 \\ 0.944 \\ 0.955 \\ 0.930 \end{bmatrix} \eta_{LIT} \quad \begin{bmatrix} SCF1 \\ SCF2 \\ SCF3 \end{bmatrix} = \begin{bmatrix} 0.960 \\ 0.952 \\ 0.932 \end{bmatrix} \eta_{SCF}$$

(1) Measurement (SOC) (2) Measurement (LIT) (3) Measurement (SCF)

The SOC dimension variable directly has a positive effect on SCF with a path coefficient value of 0.047, with significant level 0.442 or probability value is bigger than 0.05 insignificant cause-effect. Based on Figure 6, the results of causal steps and the product of coefficient indicate not complied. Where, the direct effect model of X to Y (c') is not significant in the probability value 0.442 or $p > 0.05$, meanwhile Indirect effect (ab) significant is 0.000 ($p < 0.05$), means, complete mediation occurs. The results of the consistency test show the value of the direct effect (coefficient c') X of Y is 0.047 (positive) or in the same direction with a positive value of indirect effect (ab) ($0.776 = 0.864 \times 0.900$), so, that the two mediation models in this study are consistent and have a positive effect. So they can decide to reject H0 and accept H1.

The variable of the SOC (predictor) dimension that has an indirect effect related to the SCF (criterion) is LIT (mediator). The amount of indirect effect is $0.864 \times 0.900 = 0.778$. In this condition, the policy intervention can be done to improve the performance of the SCF must involve SOC interaction in a participatory manner through an institutional approach and regulatory support.

Although LIT provides an indirect effect of 0.778, because the LIT position only functions as an intervening or mediating variable, it is difficult to observe and measure. Theoretically, intervening variables affect the relationship between independent variables and dependent variables, but it cannot be observed and measured (Fritz et al., 2012; Hayes, 2013; Hayes & Rockwood, 2016; Holland et al., 2016; Karazsia et al., 2013; Kenny & Judd, 2014). For example, the effectiveness of an extension program (LIT3) by extension workers (LIT2) affects the participation of farmers, adding the value of timber (SOC1) to welfare (SCF3). This is the right relations, but the success of farmers' participation adds to the value of timber because of a communication in the extension, so communication in the extension cannot be a specific

Commented [A29]: This is neither a sentence, is it title of sub heading or what?

Commented [A30R29]: We have removed

Commented [A31]: Where is Figure 6?

Commented [A32R31]: Yes it is

Commented [A33]: Look at previous comment

Commented [A34R33]: We have removed

conclusion for the successful participation of farmers adding value to the timber. But there is still a role for other reflective indicators from the LIT variable. SOC-SCF total effect. Total Effect of SOC on SCF is 0.825. this value is obtained by calculating: $TE = \text{Path 1 (SOC SCF)} + \text{Path 2 (SOC LIT} * \text{LIT SCF)} = 0.047 + (0.864 \times 0.900) = 0.047 + 0.778 = 0.825$.

Generally, the findings by Sukwika et al. (2016) and Tadesse dan Teketay (2020) suggested that the various independent variables that significantly affected the dependencies of local farmers on community forests also affected their levels of participation on forest management sustainability activities. Regarding institutions, Sukwika et al. (2018) found the impact of policy strategies on indicators of increasing the proportion of forestry extension personnel and increasing the quality of forestry extension program activities to the sustainability forests management. Forest plays an important role as incentives to community participation in forest management. Musyoki et al. (2016) revealed that the level of participation of community forest associations members in participatory forest management activities was positively and significantly influenced by the level of perceived participatory forest management benefits.

E. Ecology Dimension Modeling

In this study, the EGY dimension model was formed based on the results of the analysis of valid indicators used in the Measurement and variable-latent variable models that significantly reflected the structural model. From the analysis results obtained evaluation results (validation) from the measurement model that the 10 valid indicators in the measurement of each latent construct which is indicated by the loading value for all indicators greater than 0.7, so that all indicators can be used in forming the SCF model. Thus, based on Figure 7 in the SFC model that can be formed consists of two structural models and three Measurement models as follows: (1) Model of structural for latent variable EGY to ACT: $\eta_{ACT} = 0.907 \xi_{EGY}$; (2) Model of structural for latent of variable EGY and ACT to SCF: $\eta_{SCF} = 0.334 \xi_{EGY} + 0.618 \xi_{ACT}$. Model of Construct Measurement EGY, [ACT, and SCF] is:

$$\begin{bmatrix} \text{ACT1} \\ \text{ACT2} \\ \text{ACT3} \\ \text{ACT4} \end{bmatrix} = \begin{bmatrix} 0.858 \\ 0.879 \\ 0.915 \\ 0.835 \end{bmatrix} \eta_{ACT} \quad \begin{bmatrix} \text{EGY1} \\ \text{EGY2} \\ \text{EGY3} \end{bmatrix} = \begin{bmatrix} 0.959 \\ 0.950 \\ 0.934 \end{bmatrix} \eta_{EGY} \quad \begin{bmatrix} \text{SCF1} \\ \text{SCF2} \\ \text{SCF3} \end{bmatrix} = \begin{bmatrix} 0.943 \\ 0.940 \\ 0.933 \end{bmatrix} \eta_{SCF}$$

(1) Measurement (ACT) (2) Measurement (EGY) (3) Measurement (SCF)

Based on Figure 7 result of causal steps and the product of coefficient shows completed. Where the direct effect model from X to Y (c') and indirect effect (ab) significant is 0.000 (≤ 0.05), it means, mediation occurred is partial mediation. The result of consistency test shows that direct effect value (coefficient c') X to Y each 0.047 (positive) or no opposite with indirect effect (ab) with positive value ($0.561 = 0.907 \times 0.618$). It can be concluded both mediation model in this study are consistent and provide positive effect, therefore they can decide to reject H0 and accept H1.

Furthermore, if seen from the value of the direct effect (coefficient c') X to Y is -0.292 (negative), as opposed to the indirect effect (ab), is 0.250 ($= 0.557 \times 0.448$) (positive), the mediation model in this study is an inconsistent and gives negative effect. While the explanation of Figure 7 shows the results of the direct effect model of X to Y (c') and there is a mediating effect X against M and M against Y (ab) is significant at the value of 0 (Table 10). Each direction of the influence is positive, so the model mediation is consistent.

The variable of the EGY dimension has an indirect relationship to SCF is ACT. The amount of indirect effect is $= 0.907 \times 0.618 = 0.561$. In such circumstances the ACT variable functions as an intervening or mediating variable that can have an effect of 56.10 % on the sustainability of

Commented [A35]: Look at previous comment

Commented [A36R35]: We have removed

community forests. In this case, reflective indicators can explain include the high and low efficiency of land use (EGY3) for timber plants managed by community forest farmers, which will indirectly affect poverty conditions around forest villages (SCF2). There is an intermediate variable indicator, namely post-harvest wood processing (ACT3), according to Sukwika et al. (2016), Apipoonyanon et al. (2020) and Tadesse dan Teketay (2020) this condition shows that forest farmers' timber administration is highly dependent on the participation of farmers in increasing timber value added through post-harvest wood processing (above 80% variant explained). Despite, the community forest program demonstrating direct effect results to livelihood improvement, more efforts are still needed to encourage alternative income sources to enable future generations to be less dependent on the forest (Ekanayake et al., 2020; Sukwika et al., 2020).

The total effect (TE) of EGY on SCF is 0.895. This value is obtained BY calculate: TE = Path 1 (EGY SCF) + Path 2 (EGY ACT * ACT SCF) = 0.334 + (0.907 x 0.618) = 0.334 + (0.561) = 0.895. Thus, simultaneous policy intervention on the EGY dimension through its lever attribute does not necessarily give a positive effect or better than partially, or vice versa. That is, the choice of policy interventions for sustainable community forest management through the Ecology dimension can use two approaches namely simultaneous and/or partial EGY-SCF indirect effect.

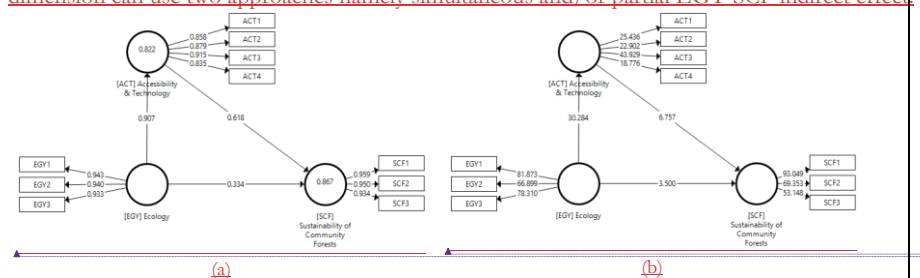

Figure 7. Diagram structural path of Ecology to Sustainability of Community Forests hasil (a) trimming and (b) bootstrapping

Baral et al. (2018) concluded that maintaining a large number of trees have direct effect to ecological but not on economical sustainability or play an indirect effect. Using exploratory factor analysis (EFA) and confirmatory factor analysis (CFA) Kusmana dan Sukwika (2018) got results feasible in goodness of fit model, where the conservation activity can prevent the degradation area from erosion. However if it is to be utilized for economic activities by the community, it should be directed to the activities which are beneficial in preserving the environment or environmental services. Baral et al. (2018) and Sukwika et al. (2018) found linkage that rationalize annual harvests across all forest categories has a direct effect on improving resource conditions along with regular benefits to local communities.

F. LIT and ACT Dimension Modeling

Therefore, based on Figure 8, in this study, SCF model can be formed by more than one structural model and three Measurement model as follows: (1) Model of structural for latent variable LIT and ACT to SCF: $\eta_{SCF} = 0.582 \xi_{LIT} + 0.408 \xi_{ACT}$. Model of Construct Measurement LIT, ACT, and SCF is:

Formatted: Font: Garamond
 Formatted: Font: Garamond

$$\begin{bmatrix} \text{ACT1} \\ \text{ACT2} \\ \text{ACT3} \\ \text{ACT4} \end{bmatrix} = \begin{bmatrix} 0.850 \\ 0.882 \\ 0.882 \\ 0.838 \end{bmatrix} \eta_{\text{ACT}} \quad \begin{bmatrix} \text{LIT1} \\ \text{LIT2} \\ \text{LIT3} \\ \text{LIT4} \end{bmatrix} = \begin{bmatrix} 0.924 \\ 0.945 \\ 0.955 \\ 0.929 \end{bmatrix} \eta_{\text{LIT}} \quad \begin{bmatrix} \text{SCF1} \\ \text{SCF2} \\ \text{SCF3} \end{bmatrix} = \begin{bmatrix} 0.959 \\ 0.951 \\ 0.934 \end{bmatrix} \eta_{\text{SCF}}$$

(1) Measurement (ACT) (2) Measurement (LIT) (3) Measurement (SCF)

Prediction of the value of an effect variable (endogenous) depends on the value of the independent variable (exogenous), this is because the prediction with path analysis is qualitative (Memon et al., 2018; Montoya, 2019; Namazi & Navid-Reza, 2016; Nitzl et al., 2016). Variable of dimension LIT and ACT each of them has a positive direct effect to SCF with path coefficient value is 0.582 and 0.408 (Table 4). Both of exogenous variable has the causal effect (significant) to endogenous variable SCF with probability value is 0 (< 0.05) then it means sufficient data to reject H₀ and accept H₁.

This section does not discuss the mediational hypothesis for the causal steps strategy, because the fulfilment requirements are not available, independent variables (predictors) must significantly affect the mediator variables (MacKinnon et al., 2012; Sarstedt et al., 2017; Turnes & Ernst, 2015; Ullman & Bentler, 2013). Based on Figure 8 shows that the variable LIT and ACT are exogenous variable (independent/predictor), so it does not have relations for an indirect effect to SCF. Therefore, the total effect value LIT and ACT is 0.582 and 0.408.

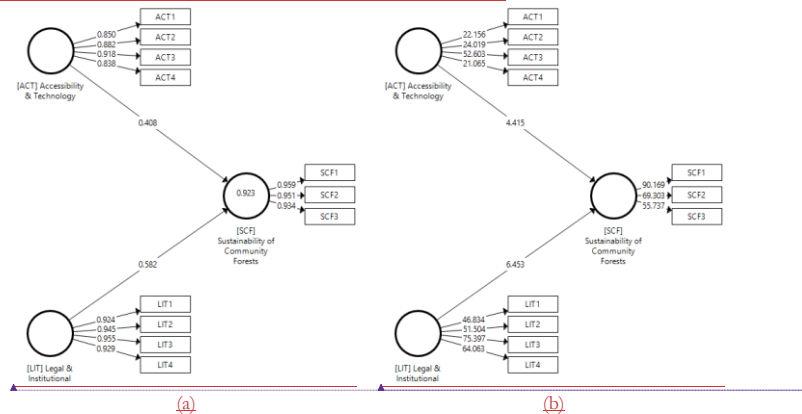

Figure 8. Diagram of Structural Path of LIT & ACT to Sustainability of Community Forests result (a) trimming and (b) bootstrapping

According to the measurement results above, the socialization relationship by the extension team regarding sustainable forest management is hampered. There is a very low effect of the extension agent role toward the perspective of forest farmers on the sustainability of community forests. Overall, institutional and accessibility influences on sustainability of community forests are adequate and weak. These obstacles can be influenced by different perspectives on sustainable forest management and a fragmented network of many different owners with a clear asymmetrical distribution of trust and power (Sukwika et al., 2020; Van Gossum et al., 2011). However, it is possible because the most powerful and trusted actors in the network - the forest group and the forest service - have the same perspective on sustainable forest management perspective as the government (Van Gossum et al., 2011).

Formatted: Font: Garamond

Formatted: Font: Garamond

Formatted: Justified

G. Dominant Effect Between Multidimensional Variables

In structural equations, to involve many variables and paths between variables, there are also relations of effects between variables which include, direct effects, indirect effects and total effects (Ghozali & Latan, 2015b; Hair et al., 2014; Vinzi et al., 2010). Summary of variables which have that 3 (three) effects to variable SCF refer to Table 4.

The indirect effect of the EGY to SCF dimension is 0.561. It shows that the rise in the EGY dimension will have an impact on the increase in SCF as a result of the Ecology dimension. So the EGY dimension provides a total effect to SCF through other mediations, namely ACT, which is 0.895. It means that each increase in the EGY dimension score by 100 % will increase the SCF score by 89.5 %. Refer to Table 4 can be obtained the direct effect ACT to SCF is 0.408.

Based on the calculation of effect total coefficient from each variable with the significant result to an endogenous variable (Table 4), can be sorted as follows:

- 1: Total effect EGY to SCF \equiv 0.895 (strong; dominant)
- 2: Total effect ECO to SCF \equiv 0.855 (strong)
- 3: Total effect SOC to SCF \equiv 0.825 (strong)
- 4: Total effect LIT to SCF \equiv 0.582 (adequate)
- 5: Total effect ACT to SCF \equiv 0.408 (weak)

The dimension of EGY is a dominant effect variable or with a robust effect on SCF. This level showed by EGY variable where has the greatest total effect coefficient value is 0.895. Figure 9 shows that simulation of total effect from dimensional variable to SCF variable. This simulation held resampling data test for 300 times reoccurrence by doing the bootstrapping technique (Afanadorac et al., 2013; Ghozali & Latan, 2015b; Hair et al., 2019; Sarstedt et al., 2017; Thoemmes et al., 2010; Ullman & Bentler, 2013). Sample in Figure 8, shows that one of the total effect variable EGY relations to SCF in Figure (a). From the figure shows that the estimation result variety is between 0.815–0.950 for its coefficient value. However, based on the simulation value, it shows the estimation coefficient with the frequency of occurrence above 15 between 0.875–0.925 for its coefficient value. EGY variable, based on the average of estimation total effect coefficient value of EGY to SCF is 0.895. This average value same with value result of a calculation, refer to Table 4.

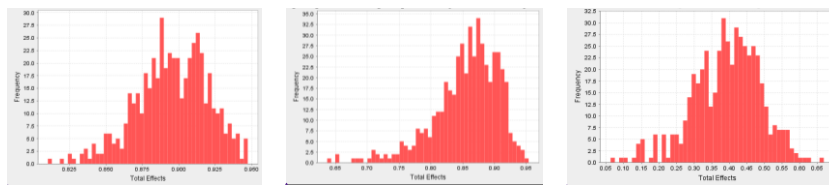

Figure (a) EGY to SCF: strong (dominant) Figure (b) ECO to SCF: strong Figure (c) ACT to SCF: weak

Figure 9. Diagram effect total variable dimensional to sustainability of community forests: (a) Ecology, (b) Economic, and (c) Accessibility & Technology

Forest farmer activities in planting, managing, developing, and sustainably utilizing plantation forests assist policy and decisionmakers, land use planners, environmental analysts, forest conservation and management experts to consider socio-economic, bio-physical, and institutional indicators that directly and indirectly effect the dependencies of local communities on forests and their levels of participation on management activities (Sukwika et al., 2018; Sukwika et al., 2020; Tadesse & Teketay, 2020; Van Gossum et al., 2011).

Research experience has found the benefits of the analysis by using PLS-SEM i.e. it does not need a large sample size that can cover hundreds or even thousands, it can simply uses few

Formatted: Justified

Formatted: Justified

Formatted: Font: Garamond

Formatted: Font: Garamond

Formatted: Font: Garamond

Formatted: Justified

observations. This research experience was also proven by Kock (2014) who stated that a measure of the magnitude of an effect is independent of the size of the sample analyzed. Other research experiences by Goodhue et al. (2012) proved that the minimum sample size on the PLS-SEM test is capable of achieving an acceptable power level. While the Kock dan Hadaya (2018) research has proven that the reliability of PLS-SEM using the inverse square root method and monte-carlo found that the inverse square root method is particularly attractive. The implications of the research results is consistent with these findings, it is our recommendation for PLS-SEM users used the inverse square root method for minimum sample size estimation. By doing so, those researchers will generate estimates that are both fairly precise and safe, with both normal and non-normal data. Costa et al. (2012) compared the potential of PLS regression and ordinary linear regression for accurate modelling of forest work, with special reference to wood chipping, wood extraction and the continuous harvesting of short rotation coppice. Compared to linear regression, PLS regression allowed producing models that better fit the original data. By producing alternative models, PLS regression may provide additional - and not alternative - ways of reading the data. Ideally, a comprehensive data analysis could include both ordinary and PLS regression and proceed from their results in order to get a better understanding of the phenomenon under examination.

IV. CONCLUSION

Sustainability dimensions of economic, ecology, legal & institutional, and accessibility & technology have significant positive direct effect on sustainability of community forests. Therefore, the higher level of sustainability in economic, ecology, legal & institutional, and accessibility & technology, the better of sustainability of community forests, vice-versa. Meanwhile, the dimension of social has no significant direct effect on sustainability of community forests. The result of mediational hypothesis testing suggested that there is a partial mediation from economic and ecology to sustainability of community forests, which is consistent and have a positive effect. Meanwhile, there is a complete mediation from social to sustainability of community forests which is inconsistent and has a negative effect. Based on the calculation of the coefficient value of total effect (direct and indirect), among the five dimensions, Ecology has the biggest value (0,895). Therefore, it concluded that ecology has the strongest effect on the sustainability of the community forest.

In contrast to the ecological dimension toward forest sustainability management, the contribution of the accessibility and technology dimension is weak, therefore, the policy implies that it is necessary to improve performance in an integrated manner in leveraging attributes of access to timber market information, logging method, and postharvest wood processing. Other concrete actions are increasing farmer participation to add value to timber and reducing poverty levels through the monthly income of farmers from non-timber forest products and agroforestry. Furthermore, related to institutions, the forestry office needs to improve quality for agricultural and forestry extension program activities, namely through periodical improvement in planning for extension programs to forest farmer groups.

ACKNOWLEDGEMENT

We wish to thank forestry agencies and BP3K Bogor regency, Ministry of Environment and Forestry, Natural Resources Conservation Center (BKSDA) in Bogor who made this work possible. Special thanks to our friends, for their valuable work in the field collecting data and the many farmer's groups who participated in the survey. Finally, thank much more to reviewers for their valuable comments to the manuscript.

- | | | | |
|----------------------------|---|-------|--------------------|
| 1: Total effect EGY to SCF | = | 0.895 | (strong; dominant) |
| 2: Total effect ECO to SCF | = | 0.855 | (strong) |

Formatted: Pattern: Clear

- 3: Total effect SOC to SCF = 0.825 (strong)
- 4: Total effect LIT to SCF = 0.582 (adequate)
- 5: Total effect ACT to SCF = 0.408 (weak)

The dimension of EGY is a dominant effect variable or with a robust effect on SCF. This level showed by EGY variable where has the greatest total effect coefficient value is 0.895. Figure 9 shows that simulation of total effect from dimensional variable to SCF variable. This simulation held resampling data test for 300 times reoccurrence by doing the bootstrapping technique (Afanadorae et al., 2013; Ghozali & Latan, 2015b; Hair et al., 2019; Sarstedt et al., 2017; Thoemmes et al., 2010; Ullman & Bentler, 2013). Sample in Figure 8, shows that one of the total effect variable EGY relations to SCF in Figure (a). From the figure shows that the estimation result variety is between 0.815–0.950 for its coefficient value. However, based on the simulation value, it shows the estimation coefficient with the frequency of occurrence above 15 between 0.875–0.925 for its coefficient value. EGY variable, based on the average of estimation total effect coefficient value of EGY to SCF is 0.895. This average value same with value result of a calculation, refer to Table 4.

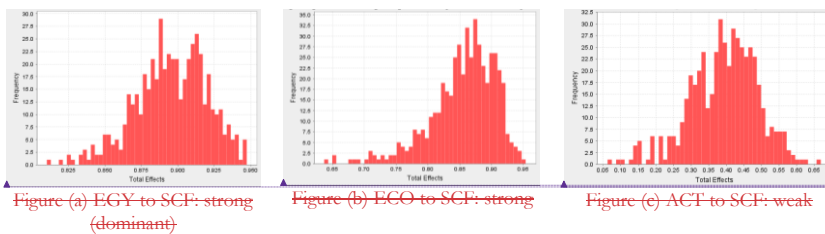

Figure 9. Diagram effect total variable dimensional to sustainability of community forests: (a) Ecology, (b) Economic, and (c) Accessibility & Technology

1. Chapter Results and Discussion need to be further elaborated and enriched. The discussion has not yet compared the results of similar studies in other areas in Indonesia and/or also in other countries to confirm, supporting the analysis model obtained. Comparison and enrichment can also be carried out by comparing with analysis models on other forms of forest management besides Community Forest. Comparisons with similar research results from other countries are needed to attract international readers of the IJFR Journal.

2. The implications of the research results and the benefits of the analysis by using PLS-SEM have not been described.

V. CONCLUSION

Sustainability dimensions of economic, ecology, legal & institutional, and accessibility & technology have significant positive direct effect on sustainability of community forest. Therefore, the higher level of sustainability in economic, ecology, legal & institutional, and accessibility & technology, the better of sustainability of community forests vice versa. Meanwhile, the dimension of social has no significant direct effect on sustainability of community forests. The result of mediational hypothesis testing suggested that there is a partial mediation from economic and ecology to sustainability of community forests, which is consistent and have a positive effect. Meanwhile, there is a complete mediation from social to sustainability of community forests which is inconsistent and has a negative effect. Based on the calculation of the coefficient value of total effect (direct and indirect), among the five dimensions, Ecology has the

Formatted: Font: (Default) Garamond

Formatted: Font: (Default) Garamond

Formatted: Font: (Default) Garamond

Formatted: Not Highlight

biggest value (0.895). Sustainability dimensions of [ECO], [EGY], [LIT], and [ACT] have significant positive direct effect on [SCF]. Therefore, the higher level of sustainability in [ECO], [EGY], [LIT], and [ACT], the better of [SCF], vice versa. Meanwhile, the dimension of [SOC] has no significant direct effect on [SCF]. The result of mediational hypothesis testing suggested that there is a partial mediation from [ECO] and [EGY] to [SCF], which is consistent and have a positive effect. Meanwhile, there is a complete mediation from [SOC] to [SCF] which is inconsistent and has a negative effect. Based on the calculation of the coefficient value of total effect (direct and indirect), among the five dimensions, Ecology has the biggest value (0.895). Therefore, it concluded that ecology has the strongest effect on the sustainability of the community forest.

In contrast to the ecological dimension toward forest sustainability management, the contribution of the accessibility and technology dimension is weak, therefore, the policy implies that it is necessary to improve performance in an integrated manner in leveraging attributes of access to timber market information, logging method, and postharvest wood processing. Other concrete actions are increasing farmer participation to add value to timber and reducing poverty levels through the monthly income of farmers from non timber forest products and agroforestry. Furthermore, related to institutions, the forestry office needs to improve quality for agricultural and forestry extension program activities, namely through periodical improvement in planning for extension programs to forest farmer groups.

What is the implication for further research and what recommendation the authors suggest for more sustainable community forest management?

acknowledgement

We wish to thank **Forestry Agency and BPSK Bogor Regency, Ministry of LHK, BKSDA** several institutions and individuals in Bogor who made this work possible. Special thanks to our friends, for their valuable work in the field collecting data and the many farmer's groups who participated in the survey. Finally, thank much more to reviewers for their valuable comments to the manuscript.

REFERENCES

- Afanadorac, N. L., Tranb, T. N., & Buydensc, M. C. (2013). Use of the bootstrap and permutation methods for a more robust variable importance in the projection metric for partial least squares regression. *Analytica Chimica Acta*, 768, 49-56. doi:10.1016/j.aca.2013.01.004
- Ali, Z., & Bhaskar, S. B. (2016). Basic statistical tools in research and data analysis. *Indian Journal of Anaesthesia*, 60(9), 662-669. doi:10.4103/0019-5049.190623
- AmirKhali, S. S. (2013). Predictive efficiency of random effects approach: A real model simulation study. *Journal of Business & Economics Research*, 11(11), 1-6.
- Apipoonyanon, C., Kuwornu, J. K. M., Szabo, S., & Shrestha, R. P. (2020). Factors influencing household participation in community forest management: evidence from Udon Thani Province, Thailand. *Journal of Sustainable Forestry*, 39(2), 184-206. doi:10.1080/10549811.2019.1632211
- Baral, S., Gautam, A. P., & Vacik, H. (2018). Ecological and economical sustainability assessment of community forest management in Nepal: A reality check. *Journal of Sustainable Forestry*, 37(8), 820-841. doi:10.1080/10549811.2018.1490188
- Baron, R. M., & Kenny, D. A. (1986). The moderator-mediator variable distinction in social psychological research: Conceptual, strategic, and statistical considerations. *Journal of Personality and Social Psychology*, 51(6), 1173-1182.

Formatted: Justified

- Bryman, A., & Bell, E. (2007). The nature of qualitative research. In *Business Research Methods* (pp. 402-437). New York: Oxford University Press.
- Carrión, G. C., Nitzl, C., & Roldán, J. L. (2017). Mediation analyses in partial least squares structural equation modeling: Guidelines and empirical examples. In H. Latan & R. Noonan (Eds.), *Partial Least Squares Path Modeling: Basic Concepts, Methodological Issues and Applications* (pp. 173-195). Cham: Springer International Publishing.
- Cham, H., West, S. G., Ma, Y., & Aiken, L. S. (2012). Estimating Latent Variable Interactions With Non-Normal Observed Data: A Comparison of Four Approaches. *Multivariate behavioral research*, 47(6), 840-876. doi:10.1080/00273171.2012.732901
- Chernick, M. R. (2011). *Bootstrap methods: A guide for practitioners and researchers*. New York: John Wiley & Sons, Inc.
- Cheung, G. W., & Lau, R. S. (2007). Testing mediation and suppression effects of latent variables: Bootstrapping with structural equation models. *Organizational Research Methods*, 11(2), 296-325. doi:10.1177/1094428107300343
- Costa, C., Menesatti, P., & Spinelli, R. (2012). Performance modelling in forest operations through partial least square regression. *Silva Fennica*, 46(2), 241-252.
- Dawson, J. F. (2014). Moderation in management research: What, why, when, and how. *Journal of business and psychology*, 29(1), 1-19.
- Eisingerich, A. B., & Rubera, G. (2010). Drivers of Brand Commitment: A Cross-National Investigation. *Journal of International Marketing*, 18(2), 64-79. doi:10.1509/jimk.18.2.64
- Ekanayake, E. M. B. P., Xie, Y., Ahmad, S., Geldard, R. P., & Nissanka, A. H. S. (2020). Community Forestry for livelihood Improvement: evidence from the intermediate zone, Sri Lanka. *Journal of Sustainable Forestry*, 1-17. doi:10.1080/10549811.2020.1794906
- Fritz, M. S., Taylor, A. B., & Mackinnon, D. P. (2012). Explanation of two anomalous results in statistical mediation analysis. *Multivariate Behavioral Research*, 47, 61-87. doi:10.1080/00273171.2012
- G-Assembly. (2005). *World Summit Outcome : resolution / adopted by the General Assembly on 16 September 2005*. (A/RES/60/1). UN General Assembly Retrieved from <https://www.un.org/>.
- Ghozali, & Latan. (2015a). *Partial Least Squares (Konsep, Teknik, dan Aplikasi Menggunakan Program SmartPLS 3.0) Untuk Penelitian Empiris*. Semarang: Badan Penerbit Undip.
- Ghozali, & Latan. (2015b). *Partial least squares: Concepts, techniques and applications using SmartPLS* (2 ed.). Semarang: Diponegoro University Press.
- Goodhue, D. L., Lewis, W., & Thompson, R. (2012). Does PLS have advantages for small sample size or non-normal data? *MIS quarterly*, 36(3), 981-1001. doi:10.2307/41703490
- Hair, J. F., Hult, G. T. M., Ringle, C., & Sarstedt, M. (2016). *A primer on partial least squares structural equation modeling (PLS-SEM)*: Sage Publications.
- Hair, J. F., Ringle, C. M., & Sarstedt, M. (2012). Partial least squares: the better approach to structural equation modeling? doi:<https://doi.org/10.1016/j.lrp.2012.09.011>
- Hair, J. F., Ringle, C. M., & Sarstedt, M. (2013). Partial least squares structural equation modeling: Rigorous applications, better results and higher acceptance. doi:<https://doi.org/10.1016/j.lrp.2013.01.001>
- Hair, J. F., Risher, J. J., Sarstedt, M., & Ringle, C. M. (2019). When to use and how to report the results of PLS-SEM. *European Business Review*, 31(1), 2-24. doi:10.1108/EBR-11-2018-0203
- Hair, J. F., Sarstedt, M., Hopkins, L., & Kuppelwieser, V. G. (2014). Partial least squares structural equation modeling (PLS-SEM): An emerging tool in business research. *European Business Review*, 26(2). doi:10.1108/EBR-10-2013-0128
- Hair, J. F., Sarstedt, M., Ringle, C. M., & Gudergan, S. P. (2017). *Advanced issues in partial least squares structural equation modeling*: SAGE Publications.
- Hayes, A. F. (2013). *Introduction to mediation, moderation, and conditional process analysis: A regression-based approach* (1st ed.). New York: The Guilford Press.

- Hayes, A. F., & Rockwood, N. J. (2016). Regression-based statistical mediation and moderation analysis in clinical research: Observations, recommendations, and implementation. *Behaviour Research and Therapy*, *98*, 39-57. doi:10.1016/j.brat.2016.11.001
- Hayes, A. F., & Scharkow, M. (2013). The relative trustworthiness of inferential tests of the indirect effect in statistical mediation analysis: Does method really matter? *Psychological Science*, *24*, 1918-1927. doi:10.1177/0956797613480187
- Holland, S. J., Shore, D. B., & Cortina, J. M. (2016). Review and recommendations for integrating mediation and moderation. *Organizational Research Methods*, *20*(4), 686-720. doi:10.1177/1094428116658958
- Karazsia, B. T., Berlin, K. S., Armstrong, B., Janicke, D. M., & Darling, K. E. (2013). Integrating mediation and moderation to advance theory development and testing. *J Pediatr Psychol.*, *39*(2), 163-173. doi:10.1093/jpepsy/jst080
- Kenny, D. A. (2008). Reflections on mediation. *Organizational Research Methods*, *11*(2), 353-358.
- Kenny, D. A., & Judd, C. M. (2014). Power anomalies in testing mediation. *Psychological Science*, *25*(2), 334-339. doi:10.1177/0956797613502676
- Kock, N. (2014). *Stable P value calculation methods in PLS-SEM*. Laredo, TX: ScriptWarp Systems.
- Kock, N., & Hadaya, P. (2018). Minimum sample size estimation in PLS-SEM: The inverse square root and gamma-exponential methods. *Information Systems Journal*, *28*(1), 227-261. doi:10.1111/isj.12131
- Kusmana, C., & Sukwika, T. (2018). Coastal community preference on the utilization of mangrove ecosystem and channelbar in Indramayu, Indonesia. *AACL Bioflux*, *11*(3), 905-918.
- MacKinnon, D., Cox, S., & Baraldi, A. N. (2012). Guidelines for the investigation of mediating variables in business research. *Journal of Business Psychology*, *27*, 1-14. doi:10.1007/s10869-011-9248-z
- MacKinnon, D., Lockwood, C. M., Hoffman, J. M., West, S. G., & Sheets, V. (2002). A comparison of methods to test mediation and other intervening variable effects. *Psychological Methods*, *7*, 83-104.
- Malhotra, N. K. (2017). *Marketing Research : An applied approach*. Harlow: Pearson Education Limited.
- Maslowsky, J., Jager, J., & Hemken, D. (2015). Estimating and interpreting latent variable interactions: A tutorial for applying the latent moderated structural equations method. *International journal of behavioral development*, *39*(1), 87-96. doi:10.1177/0165025414552301
- Memon, M. A., Cheah, J.-H., & Ramayah, T. (2018). Mediation analysis issues and recommendations. *Journal of Applied Structural Equation Modeling*, *2*(1), 1-9.
- Montoya, A. K. (2019). Moderation analysis in two-instance repeated measures designs: Probing methods and multiple moderator models. *Behav Res Methods.*, *51*(1), 61-82. doi:10.3758/s13428-018-1088-6
- Muller, D. (2013). *Design characteristics of virtual learning environments: A theoretical integration and empirical test of technology acceptance and is success research*. Saarbrücken: Springer Gabler.
- Munasinghe, M. (1992). *Environmental economics and sustainable development*. Paper presented at the UN Earth Summit, Rio de Janeiro.
- Musyoki, J. K., Mugwe, J., Mutundu, K., & Muchiri, M. (2016). Factors influencing level of participation of community forest associations in management forests in Kenya. *Journal of Sustainable Forestry*, *35*(3), 205-216. doi:10.1080/10549811.2016.1142454
- Namazi, M., & Navid-Reza, N. (2016). Conceptual analysis of moderator and mediator variables in business research. *Economics and Finance*, *36*, 540-554. doi:10.1016/S2212-5671(16)30064-8
- Nitzl, C., Roldan, J. L., & Cepeda, G. (2016). Mediation analysis in partial least squares path modelling: Helping researchers discuss more sophisticated models. *Industrial Management & Data Systems*, *116*(9), 1849-1864. doi:10.1108/IMDS-07-2015-0302

- Paul, E. J. (2013). *Doing statistical mediation and moderation (methodology in the social sciences)* (1st ed.). New York: Guilford Press.
- Preacher, K., & Hayes, A. (2008). Asymptotic and resampling strategies for assessing and comparing indirect effects in multiple mediator models. *Behavior research methods*, *40*, 879-891. doi:10.3758/BRM.40.3.879
- Preacher, K. J., & Hayes, A. F. (2004). SPSS and SAS procedures for estimating indirect effects in simple mediation models. *Behavior Research Methods, Instruments, & Computers*, *36*(4), 717-731.
- Sarstedt, M., Ringle, C. M., & Hair, J. F. (2017). Partial least squares structural equation modeling. In C. H. e. al. (Ed.), *Handbook of Market Research* (pp. 41). New York: Springer International Publishing AG.
- Singh, A. S., & Masuku, M. B. (2014). Sampling techniques and determination of sample size in applied statistics research: An overview. *International Journal of Economics, Commerce and Management*, *2*(11), 1-22.
- Sukwika, T., Darusman, D., Kusmana, C., & Nurrochmat, D. R. (2016). Evaluating the level of sustainability of privately managed forest in Bogor, Indonesia. *Biodiversitas, Journal of Biological Diversity*, *17*(1), 241-248. doi:10.13057/biodiv/d170135
- Sukwika, T., Darusman, D., Kusmana, C., & Nurrochmat, D. R. (2018). Policy scenarios for managing of sustainability private-forests in Bogor regency. *Journal of Natural Resources and Environmental Management*, *8*(2), 207-215. doi:10.29244/jpsl.8.2.207-215
- Sukwika, T., Yusuf, D. N., & Suwandhi, I. (2020). The institutional of local community and stratification of land ownership in surrounding community forests in Bogor. *Jurnal Manajemen Hutan Tropika*, *26*(1), 59-71. doi:10.7226/jtfm.26.1.59
- Taber, K. S. (2016). The use of cronbach's alpha: When developing and reporting research instruments in science education. *Research in Science Education*, *2*(2), 1-24. doi:10.1007/s11165-016-9602-2
- Tadesse, S. A., & Teketay, D. (2020). Determinant Factors Predicting the Dependencies of Local Communities on Plantation Forests and Their Levels of Participation on Management Activities in Basona Worena District, Ethiopia. *Journal of Sustainable Forestry*, *39*(8), 800-826. doi:10.1080/10549811.2020.1730907
- Tenenhaus, M., Vinzi, V. E., Chatelin, Y. M., & Lauro, C. (2005). PLS path modeling. *Computational Statistics & Data Analysis*, *48*(1), 159-205. doi:10.1016/j.csda.2004.03.005
- Thoemmes, F., MacKinnon, D. P., & Reiser, M. R. (2010). Power analysis for complex mediational designs using Monte Carlo methods. *Structural Equation Modeling*, *17*, 510-534.
- Turnes, P. B., & Ernst, R. (2015). Strategies to measure direct and indirect effects in multi-mediator models. *Business Review*, *14*(10), 504-514. doi:10.17265/1537-1514/2015.10.003
- Ullman, J. B., & Bentler, P. M. (2013). Structural equation modeling. In I. B. Weiner (Ed.), *Handbook of Psychology* (Second ed., pp. 661-690). New York: John Wiley & Sons, Inc.
- Ursachi, G., Horodnic, I. A., & Zait, A. (2015). How reliable are measurement scales? External factors with indirect influence on reliability estimators. *Economics and Finance*, *20*, 679-686. doi:10.1016/S2212-5671(15)00123-9
- Valentini, F., & Damasio, B. F. (2016). Average variance extracted and composite reliability: Reliability coefficients. *Psicologia: Teoria e Pesquisa*, *32*(2), 1-7. doi:10.1590/0102-3772e322225
- Van Gossum, P., Arts, B., De Wulf, R., & Verheyen, K. (2011). An institutional evaluation of sustainable forest management in Flanders. *Land use policy*, *28*(1), 110-123. doi:10.1016/j.landusepol.2010.05.005
- Vinzi, V. E., Chin, W. W., Henseler, J., & Wang, H. (2010). *Handbook of partial least squares: Concepts, methods and applications*: Springer Publishing Company, Incorporated.
- Yamane, T. (1967). *Statistics: An introductory analysis* (2nd ed.). New York: Harper and Row.

| Yzerbyt, V., Muller, D., Batailler, C., & Judd, C. M. (2018). New recommendations for testing indirect effects in mediational models: The need to report and test component paths. *Journal of Personality and Social Psychology, 115*(6), 929-943. doi:10.1037/pspa0000132
|